

1133 is known as: 1133-USA

1133-USA bulb specifications:

category: **Miniature**

volt: **6.2**

amp: **3.9**

watt: **24.2**

base: **BA15s** - Single Contact Candelabra Bayonet (or S.C.Bayonet)

glass: **RP11**

filament: **C2R**

fil.res.: **1.59** ohm

m.o.l.: **2.25** inches

l.c.l.: **1.25** inches

i.lumens: **402**

cp: **32**

d.hours: **200**

notes: **Aircraft Lamp**

Automotive Lamp

ground service lamp

Headlamp

interior

spot lamp

uses socket: [DB-BA15S1](#)

1133-USA

also known as

Cross-Reference:

1133-USA

031293401748

031293401748-EIKO

094-502

094-502-LEITZ

10-LUCAS

106-BMC

106-BTH

106-LUCAS

106-MAZDA

106-OSRAM

1067-TUNGSRAM

107-LUCAS

11-LUCAS

1133

1133-EIKO

1133-GE

1133-LECTRA

1133-LUGON

1133-MAZDA

1133-STANLEY

1133-SYL

1133-SYLVANIA

1133-TENSOR

1133-WESTINGHOUSE

15565-1

3121-FOCUS

35-LUCAS

37304-3

40-LUCAS

418-TRIFA

44-LUCAS

5013

5013-STANLEY

6.2-024-04

6211 [alternate 2]

6211-P

6211-PHILIPS

6211P

6240-00-155-8687

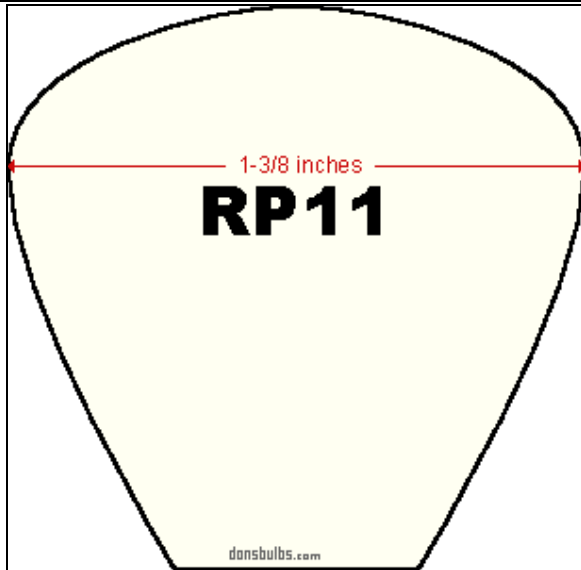

usual shape of **RP11** glass envelopes (not to scale)

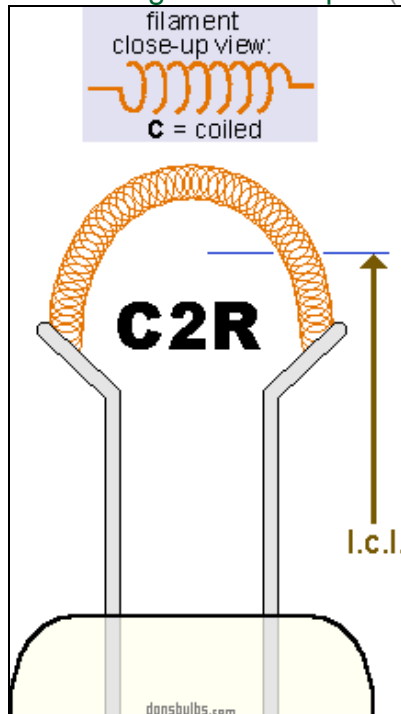

typical shape of **C2R** filament (not to scale)

6240001558687
 6V-32CP
 6V32CP
 72-LUCAS
 74-LUCAS
 7562
 7562-O
 7562-OS
 7562-OSRAM
 76-LUCAS
 77-LUCAS
 A3121
 A5013
 AB3901
 AGI-4311
 AH-4311
 AH-4311-AIDLITE
 AH4311
 AH4311-AIDLITE
 AH5301
 BC-1133
 BC1133
 CM1133
 FOCUS-3121
 MB-11330
 MB11330
 O-7562
 OS-7562
 OS7562
 P-6211
 P6211
 STANLEY-5013

BA15s B15s

single contact bayonet

SC bayonet

single contact candelabra bayonet

SCC (British single centre contact)

IEC7004-11A9
DIN49720

IEC7005-13
DIN49642T8

E25W
E15W
G15W
P21W
R5W
R10W
R18W
R21W
U45W

A18B
A18C
A18F
A18G
SCC
SC

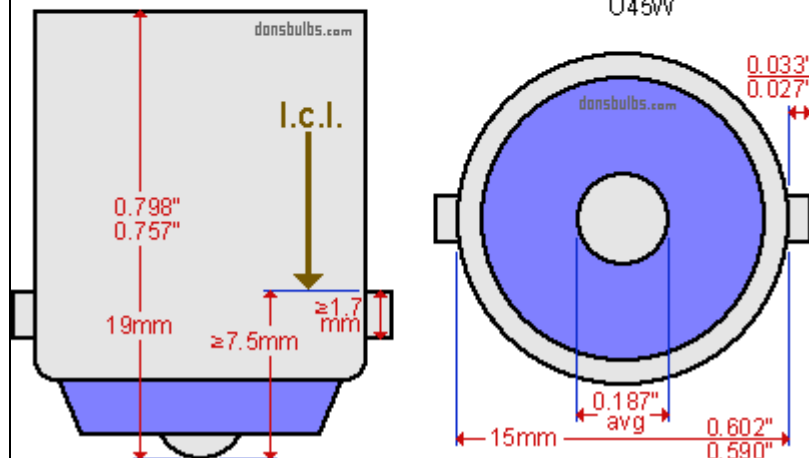

industry standards for base:

BA15s - Single Contact Candelabra Bayonet (or S.C.Bayonet)
(not to scale)

1133-USA

have been found in equipment:

Buick

1953-SERIES-40 BACK-UP-LAMP Automobile

Chevrolet

1953 BACK-UP-LAMP Automobile

1954 BACK-UP-LAMP Automobile

Chicago Coin

SPEEDWAY AND MOTORCYCLE DRIVING GAMES Coin-Op

E.Leitz Incorporated

094-502 Microscope

Ford

1953 BACK-UP-LAMP Automobile

1954 BACK-UP-LAMP Automobile

GMC

1955-6-VOLT DIRECTION-LAMP Automobile / Truck

1955-6-VOLT STOP-LAMP Automobile / Truck

Hudson

1953 BACK-UP-LAMP Automobile

1954 BACK-UP-LAMP Automobile

1955-6-VOLT BACK-UP-LAMP Automobile

Kaiser

1953 BACK-UP-LAMP Automobile

1954 BACK-UP-LAMP Automobile

1955-6-VOLT BACK-UP-LAMP Automobile

Nash

1953 BACK-UP-LAMP Automobile

1954 BACK-UP-LAMP Automobile

1955-6-VOLT BACK-UP-LAMP Automobile

Packard

1953 BACK-UP-LAMP Automobile

1954 BACK-UP-LAMP Automobile

Studebaker

1953 BACK-UP-LAMP Automobile

1955-6-VOLT BACK-UP-LAMP Automobile

Willys

1954 BACK-UP-LAMP Automobile