

2330-USA

2330-USA bulb specifications:

category: **Miniature**

volt: **6.2 / 6.2**

amp: **4.03 / 4.03**

watt: **25 / 25**

base: **P15d30** - Double Contact Prefocus Flanged

also known as Double Contact Prefocus Bayonet

also known as **P15d** (Europe)

also known as **P30d** (USA)

glass: **RP11**

filament: **C2V/C2V**

fil.res.: **1.54 / 1.54** ohm

m.o.l.: **2.25** inches

l.c.l.: **1.13** inches

i.lumens: **32 / 32**

cp: **1**

d.hours: **200**

notes:

Automotive Lamp

Headlight

uses socket: [DB-P15D30-1](#)

2330-USA

also known as **Cross-Reference:**

2330-USA

2330

2330-GE

2330-MAZDA

2330-TUNGSOL

2330-WESTINGHOUSE

2330GE

3520-TRIFA

3716-FOCUS

5616

5616-STANLEY

642690M-MICROLAMP

7578

7578-O

7578-OS

7578-OSRAM

AH-4611

AH-4611-AIDLITE

AH4611

AH4611-AIDLITE

AH5601

FOCUS-3716

O-3716

O-7578

O3716

OS7578

STANLEY-5616

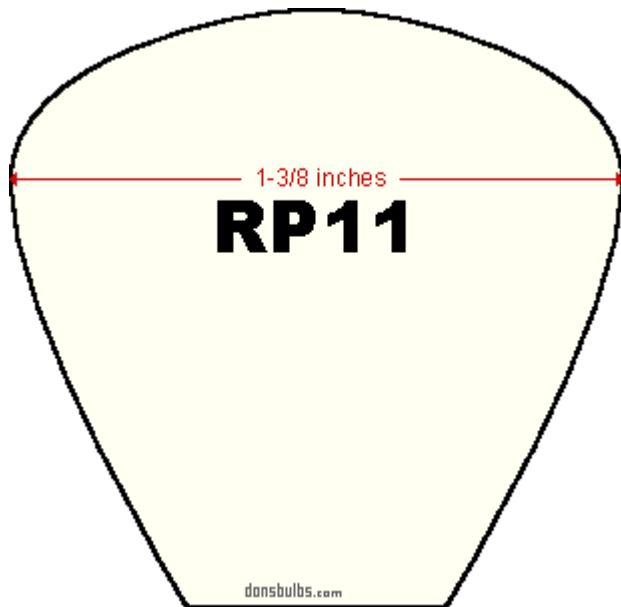

usual shape of **RP11** glass envelopes (not to scale)

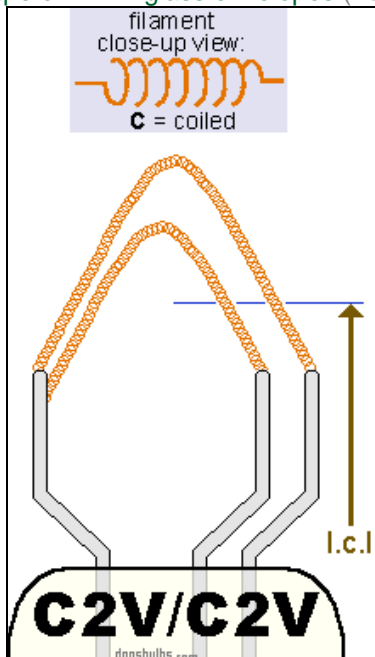

typical shape of **C2V/C2V** filament (not to scale)

2330-USA have been found in equipment:

Buick

- 1937 HEADLAMP Automobile
- 1938 HEADLAMP Automobile
- 1939 HEADLAMP Automobile

Cadillac

- 1937 HEADLAMP Automobile
- 1938 HEADLAMP Automobile

Chevrolet

- 1937 HEADLAMP Automobile
- 1938 HEADLAMP Automobile
- 1939-COACH HEADLAMP Automobile
- 1939-SEDAN HEADLAMP Automobile
- 1939 HEADLAMP Automobile

Crosley

- 1940 HEADLAMP Automobile
- 1948 HEADLAMP Automobile

Ford

- 1937 HEADLAMP Automobile
- 1938 HEADLAMP Automobile
- 1939 HEADLAMP Automobile

Graham

- 1938 HEADLAMP Automobile
- 1939 HEADLAMP Automobile
- 1940 HEADLAMP Automobile
- 1941 HEADLAMP Automobile

Hupmobile

- 1938 HEADLAMP Automobile
- 1939 HEADLAMP Automobile
- 1940 HEADLAMP Automobile
- 1941 HEADLAMP Automobile

La Salle

- 1939 HEADLAMP Automobile

Lincoln Zephyr

- 1936 HEADLAMP Automobile
- 1938 HEADLAMP Automobile
- 1939 HEADLAMP Automobile

P15d30

double contact prefocus

DC prefocus

double contact candelabra prefocus

A26
DCP

P15d
P30d
P30d-10.3
P30da

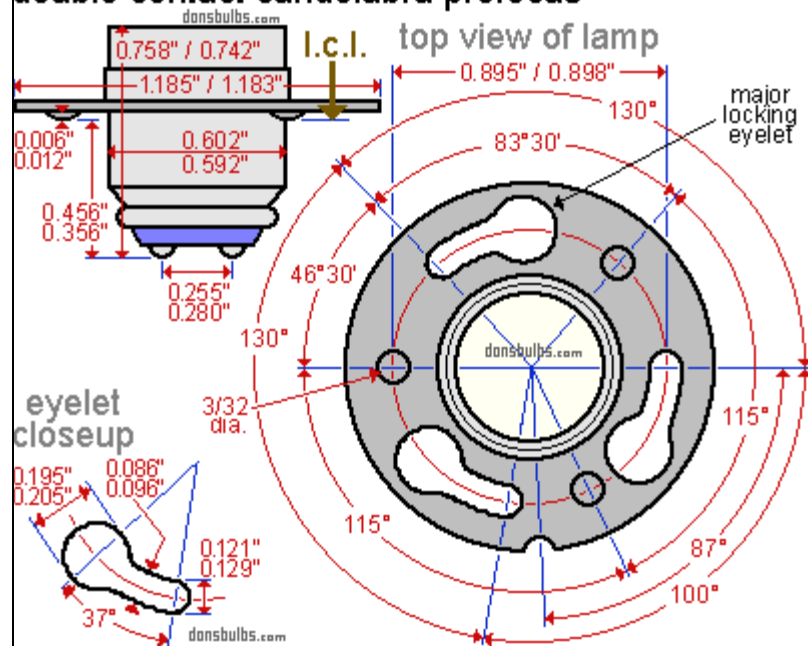

industry standards for base:

P15d30 - Double Contact Prefocus Flanged
also known as Double Contact Prefocus Bayonet
also known as **P15d** (Europe)
also known as **P30d** (USA) (not to scale)

Mercury

1939 HEADLAMP Automobile

Oldsmobile

1937 HEADLAMP Automobile

1938 HEADLAMP Automobile

1939 HEADLAMP Automobile

Packard

1937 HEADLAMP Automobile

1938-6,120 HEADLAMP Automobile

1938-SUPER-8,12 HEADLAMP Automobile

1938-SUPER8,12 HEADLAMP Automobile

1939-12 HEADLAMP Automobile

1939-6,120,SUPER-8 HEADLAMP Automobile

1939-6,120,SUPER8 HEADLAMP Automobile

Pontiac

1937 HEADLAMP Automobile

1938 HEADLAMP Automobile

1939 HEADLAMP Automobile

Willys

1937 HEADLAMP Automobile

1938 HEADLAMP Automobile

1939 HEADLAMP Automobile

1940 HEADLAMP Automobile

1941 HEADLAMP Automobile

1942 HEADLAMP Automobile