

2331-USA

2331-USA bulb specifications:

category: **Miniature**

volt: **6**

amp: **4.5 / 4.5**

watt: **27 / 27**

base: **P15d30** - Double Contact Prefocus Flanged

also known as Double Contact Prefocus Bayonet

also known as **P15d** (Europe)

also known as **P30d** (USA)

glass: **RP11**

filament: **C6/C6**

fil.res.: **1.33 / 1.33** ohm

m.o.l.: **2.25** inches

l.c.l.: **1.13** inches

i.lumens: **12.6**

cp: **1**

d.hours: **400**

notes:

clear or opaque glass top Headlight

paint top with high heat black muffler paint to make opaque

scrape opaque paint off to make clear

usually clear top available

uses socket: [DB-P15D30-1](#)

2331-USA

also known as **Cross-Reference:**

2331-USA

06-027-67DF

06-027-67DF-CANIMPEX

2305 [alternate 2]

2305-BECKMAN

2331

2331-BOWES

2331-CARLTON

2331-GE

2331-MAZDA

2331-SOLITE

2331-TUNGSOL

2331-WESTINGHOUSE

2331GE

8000152

GE2331

MB-23310

MB23310



typical photo of 2331-USA bulb type (your bulb may look slightly different)

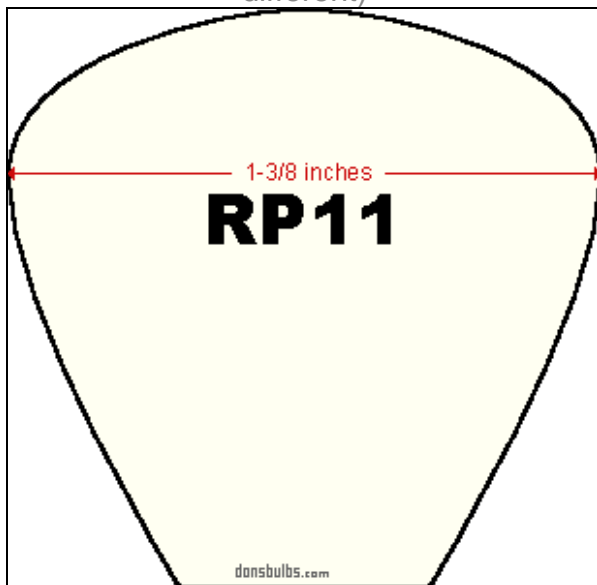

usual shape of RP11 glass envelopes (not to scale)

2331-USA

have been found in equipment:

Chrysler

1937-C-17 HEADLAMP Automobile
1937-C17 HEADLAMP Automobile
1937 HEADLAMP Automobile
1938 HEADLAMP Automobile
1939 HEADLAMP Automobile

Desoto

1937 HEADLAMP Automobile
1938 HEADLAMP Automobile
1940 HEADLAMP Automobile

Dodge

1936 HEADLAMP Automobile
1938 HEADLAMP Automobile
1939 HEADLAMP Automobile

Hudson

1937 HEADLAMP Automobile
1938 HEADLAMP Automobile
1939 HEADLAMP Automobile

Nash

1937 HEADLAMP Automobile
1938 HEADLAMP Automobile
1939 HEADLAMP Automobile

Plymouth

1936 HEADLAMP Automobile
1937 HEADLAMP Automobile
1938 HEADLAMP Automobile
1939 HEADLAMP Automobile

Studebaker

1937 HEADLAMP Automobile
1938 HEADLAMP Automobile
1939 HEADLAMP Automobile

P15d30

double contact prefocus

DC prefocus

double contact candelabra prefocus

A26
DCP

P15d
P30d
P30d-10.3
P30da

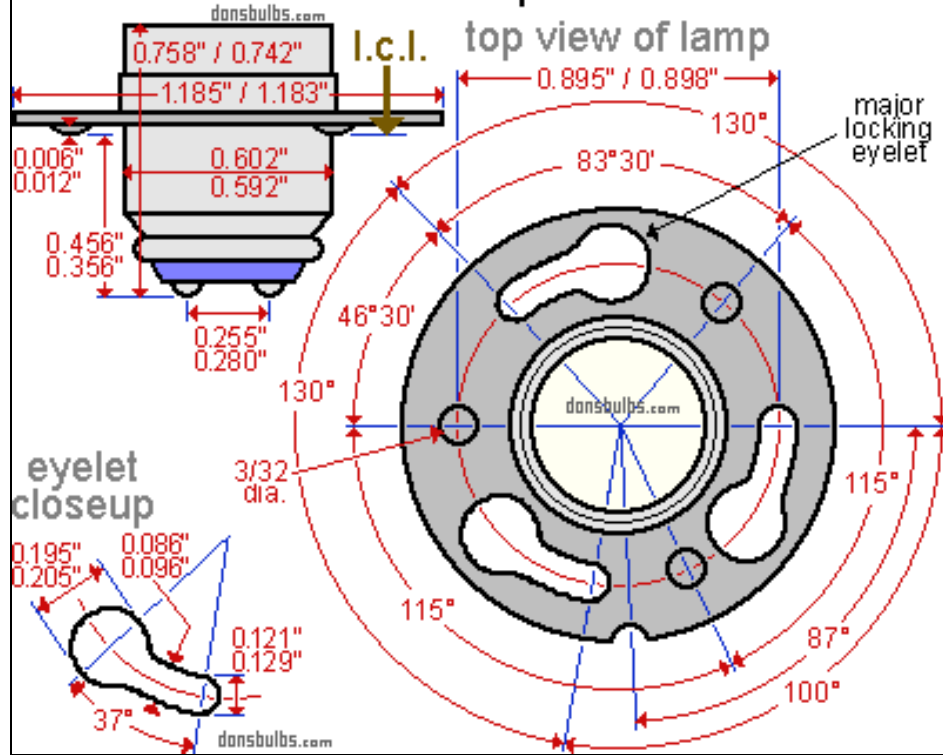

industry standards for base:

P15d30 - Double Contact Prefocus Flanged
also known as Double Contact Prefocus Bayonet
also known as **P15d** (Europe)
also known as **P30d** (USA) (not to scale)

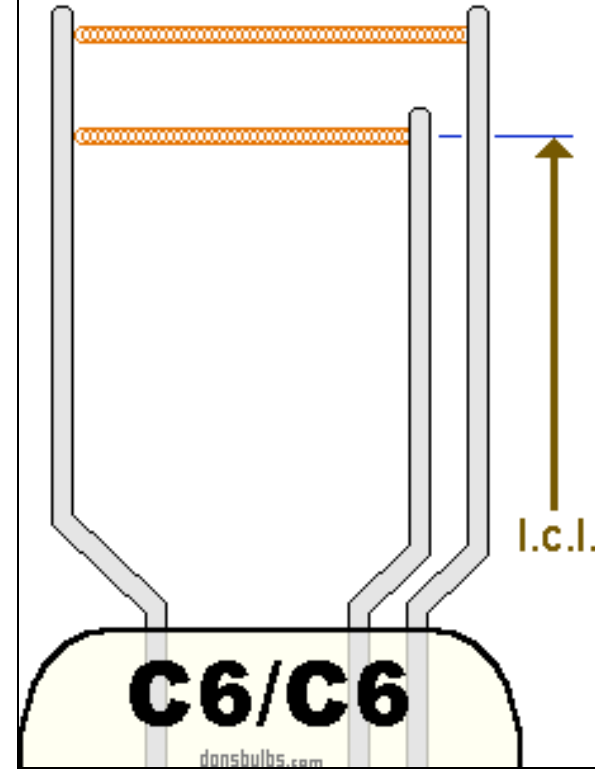

typical shape of C6/C6 filament (not to scale)