

2531 is known as: 2531-USA

2531-USA bulb specifications:

category: **Specialty**

volt: **6 - 8**

base: **P15d30** - Double Contact Prefocus Flanged

also known as Double Contact Prefocus Bayonet

also known as **P15d** (Europe)

also known as **P30d** (USA)

glass: **RP11**

filament: **C6/C6**

i.lumens: **19.6**

cp: **1.6**

notes:

antique

Automotive Lamp

Headlight

uses socket: [DB-P15D30-1](#)

2531-USA also known as Cross-Reference:

2531-USA

2531

2531-GE

2531-MAZDA

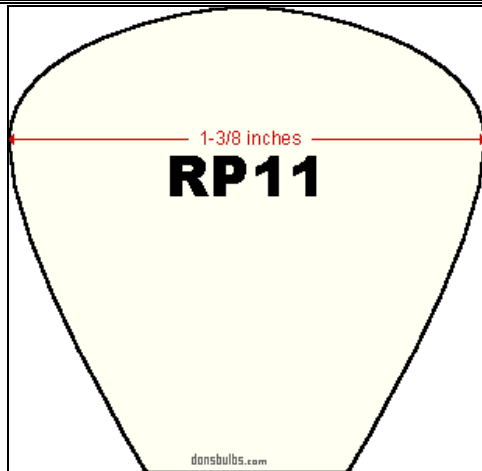

usual shape of **RP11** glass envelopes (not to scale)

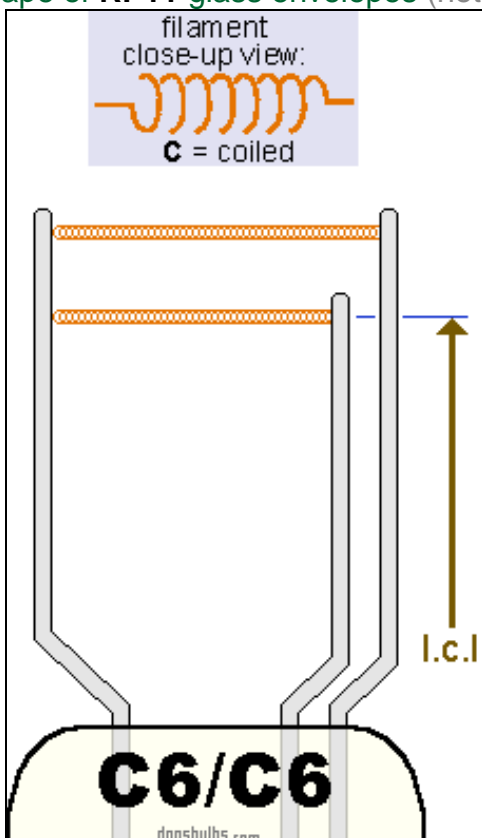

typical shape of **C6/C6** filament (not to scale)

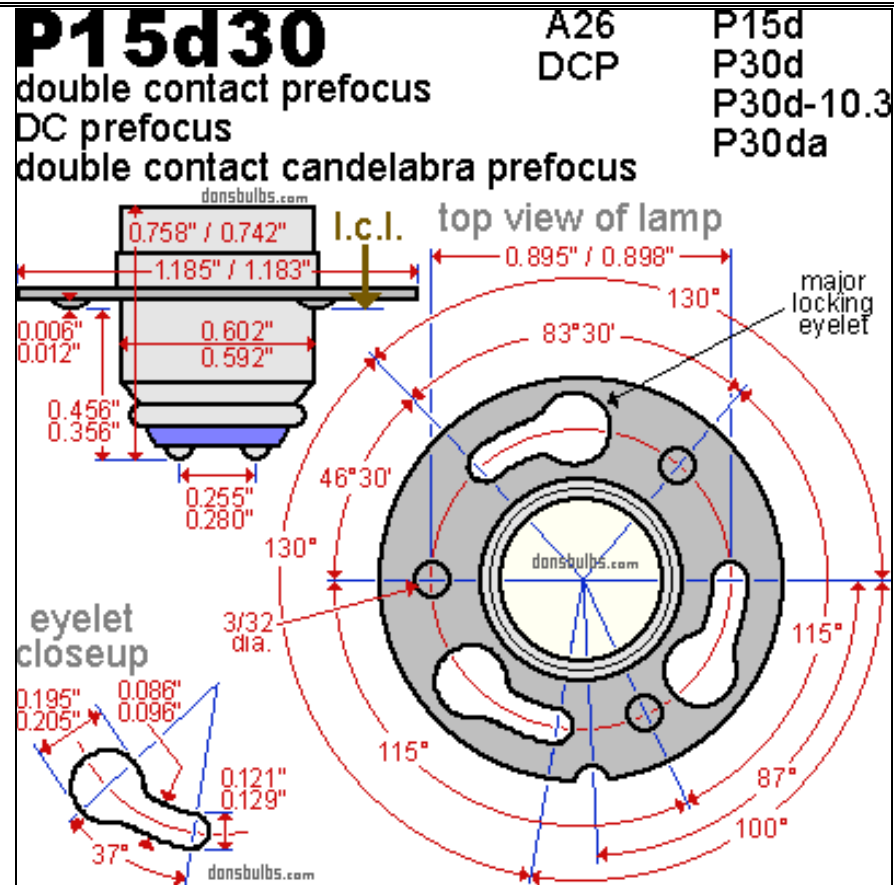

industry standards for base:
P15d30 - Double Contact Prefocus Flanged
 also known as Double Contact Prefocus Bayonet
 also known as **P15d** (Europe)
 also known as **P30d** (USA)
 (not to scale)