

1073 \$5.10

1073 USA bulb specifications:

category: **MINIATURE**

volt: **12.8**

amp: **1.8**

watt: **23**

base: **BA15s** - Single Contact Candelabra Bayonet (or S.C.Bayonet)

glass: **S8**

filament: **C6**

fil.res.: **7.11** ohm

m.o.l.: **2** inches

l.c.l.: **1.25** inches

burn pos: burn lamp in **ANY** position

i.lumens: **402**

cp: **32**

d.hours: **200**

notes:

automobile lamp

clear glass

flasher lamp

FOR 6 VOLT USE: **1133 USA**

incandescent

stop lamp

uses socket: **DB-BA15S1**

1073 USA have been found in equipment:

Borg Warner Educational Systems

D-6 Projector Slide

D-VI Projector Slide

D6 Projector Slide

DVI Projector Slide

Buick

1953-SERIES-50 BACK-UP-LAMP Automobile

1953-SERIES-50 DIRECTION-SIGNAL-

REAR Automobile

1953-SERIES-70 BACK-UP-LAMP Automobile

1953-SERIES-70 DIRECTION-SIGNAL-

REAR Automobile

1954-12-VOLT DIRECTION-SIGNAL-REAR Automobile

1954 BACK-UP-LAMP Automobile

1955-12-VOLT-40,50,60,70 BACK-UP-LAMP Automobile

1956 BACK-UP-LAMP Automobile

1957-12-VOLT DIRECTION-SIGNAL-REAR Automobile

1957-12-VOLT STOP-LAMP Automobile

1957 BACK-UP-LAMP Automobile

Cadillac

1073 USA

also known as

Cross-Reference:

2/S/8

2/S8

2S/8

2S8

12/32CANDLE-POWER/BA15S

12/32CANDLE-POWER/SC

12V-32CP-1.8A-BA15S

12V-32CP-1.8A-SC

12V/32CANDLE-POWER/BA15S

12V/32CANDLE-POWER/SC

12V32CANDLE-POWER/BA15S

12V32CANDLE-POWER/SC

12.8-023-04

12.8-023-04 CANIMPEX

37 BTH

37 LUCAS

37 MAZDA

199 BTH

199 LUCAS

199 MAZDA

403 TRIFA

1057 TUNGSRAM

1073

1073 AC/DELCO

1073 AIDLITE

1073 CHICAGO-MINIATURE

1073 EIKO

1073 GENERAL-ELECTRIC

1073 GMH

1073 LUGON

1073 NORMA

1073 NORMAN

1073 USA

1073 WESTINGHOUSE

1356 TRIFA

2561 FOCUS

4527 STANLEY

6240-00-673-0991

20402-4

35478-1073

35478-1073-MILITARY-STANDARD

454646 GENERAL-MOTORS

1953 BACK-UP-LAMP Automobile
 1954 BACK-UP-LAMP Automobile
 1955-12-VOLT BACK-UP-LAMP Automobile
 1956-12-VOLT BACK-UP-LAMP Automobile
 1957 BACK-UP-LAMP Automobile
Chevrolet
 1955-12-VOLT BACK-UP-LAMP Automobile
 1956-12-VOLT BACK-UP-LAMP Automobile
 1957-12-VOLT DIRECTION-SIGNAL-REAR Automobile
 1957 BACK-UP-LAMP Automobile
 1957 DIRECTION-LAMP Automobile / Truck
Chrysler
 1957 BACK-UP-LAMP Automobile
Desoto
 1957 BACK-UP-LAMP Automobile
Dodge
 1956 DIRECTION-LAMP Automobile / Truck
 1957 BACK-UP-LAMP Automobile
 1957 DIRECTION-LAMP Automobile / Truck
Ford
 1957-12-VOLT DIRECTION-LAMP Automobile / Truck
Hudson
 1956-12-VOLT BACK-UP-LAMP Automobile
 1957-12-VOLT BACK-UP-LAMP Automobile
Lincoln Zephyr
 1956-12-VOLT DIRECTION-SIGNAL-FRONT Automobile
Nash
 1956-12-VOLT BACK-UP-LAMP Automobile
 1957-12-VOLT BACK-UP-LAMP Automobile
Oldsmobile
 1953 BACK-UP-LAMP Automobile
 1954 BACK-UP-LAMP Automobile
 1955 BACK-UP-LAMP Automobile
 1956 BACK-UP-LAMP Automobile
 1957 BACK-UP-LAMP Automobile
Packard
 1955-12-VOLT BACK-UP-LAMP Automobile
 1956 BACK-UP-LAMP Automobile
 1957 BACK-UP-LAMP Automobile
Piper
 PA34-200T Aircraft
Plymouth
 1957 BACK-UP-LAMP Automobile
Pontiac
 1955-12-VOLT BACK-UP-LAMP Automobile
 1956-12-VOLT BACK-UP-LAMP Automobile
 1957 BACK-UP-LAMP Automobile

1547129 GENERAL-MOTORS
 031293401656 EIKO
 031293480163 EIKO
 A/4527 EIKO
 A/4527/BLISTER-PACK EIKO
 A/4527BLISTER-PACK EIKO
 A4527 EIKO
 A4527/BLISTER-PACK EIKO
 A4527BLISTER-PACK EIKO
 AGI/3416
 AGI/AS/814
 AGI/AS814
 AGI3416
 AS/3624 AIDLITE
 AS/4614
 AS3624 AIDLITE
 AS4614
 L1073 AC/DELCO
 M/2941
 M2941
 MB/10730
 MB10730

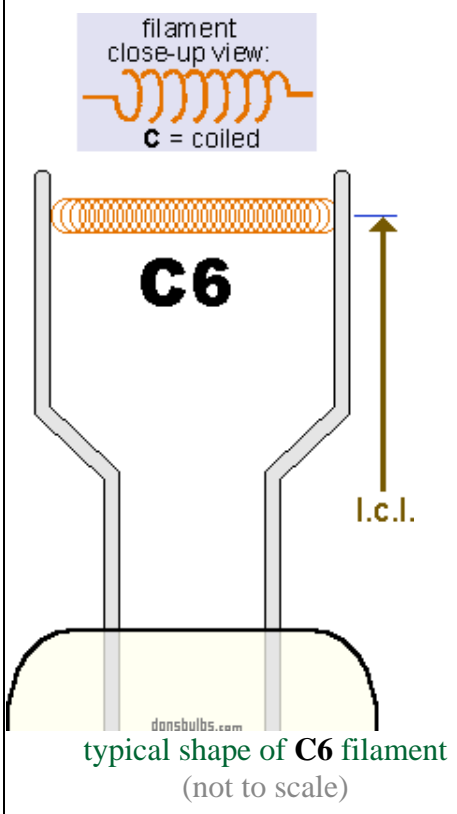

Studebaker

1956-12-VOLT BACK-UP-LAMP Automobile
1957 BACK-UP-LAMP Automobile

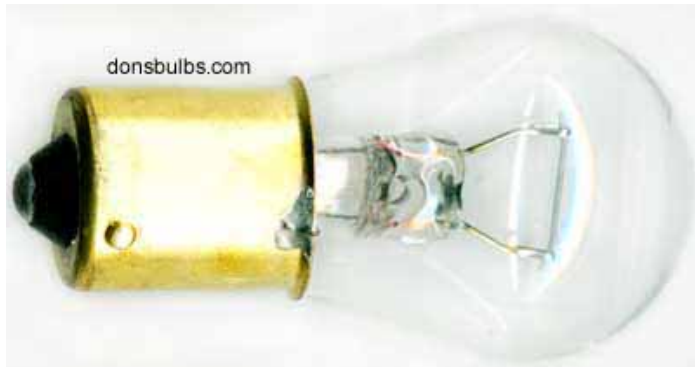

typical photo of **1073 USA** bulb type
(your bulb may look slightly different)

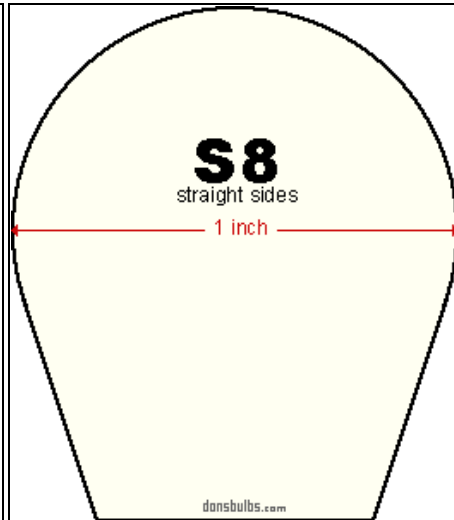

typical shape of **S8** glass envelopes
(not to scale)

BA15s

B15s

IEC7004-11A9

A18B

single contact bayonet

DIN49720

A18C

SC bayonet

IEC7005-13

A18F

single contact candelabra bayonet

DIN49642T6

A18G

SCC (British single centre contact)

E
E25W
F
F15W
G
P
P21W
R
R5W
R10W
R18W
R21W
U
U45W

SCC
SC

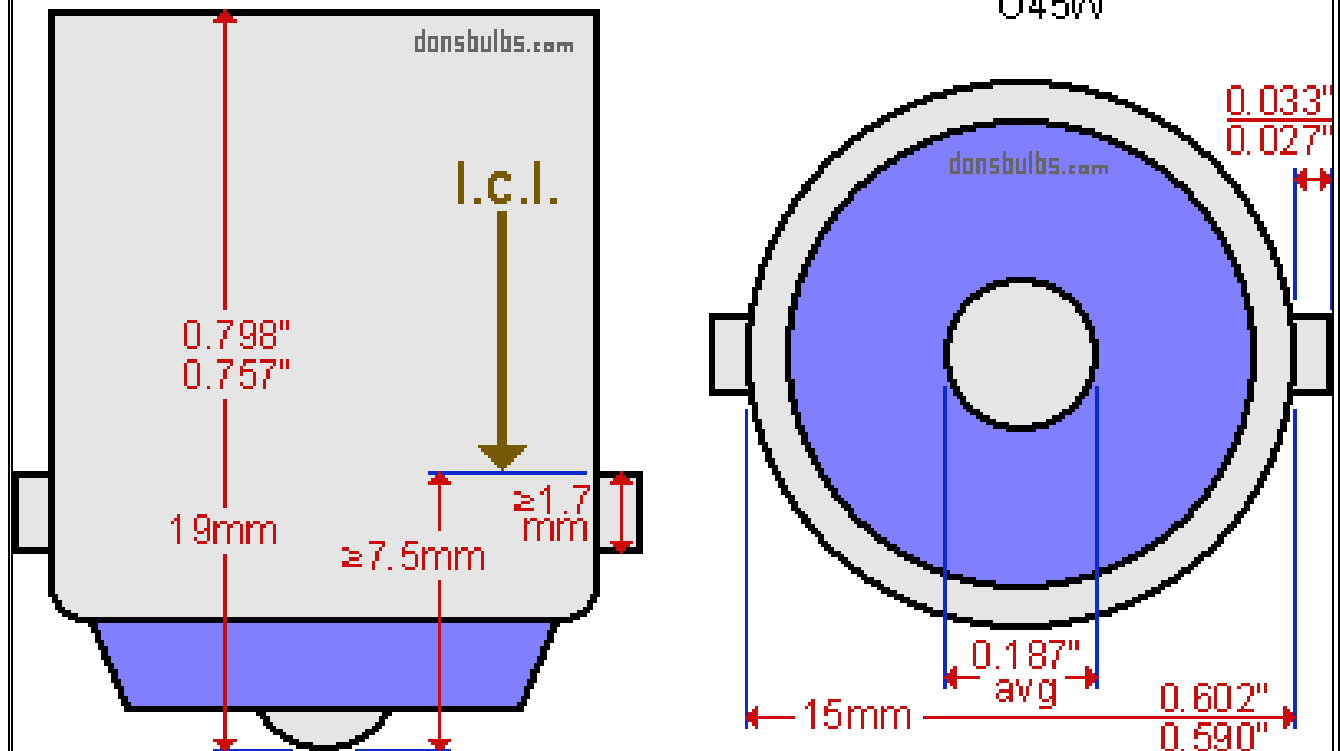

industry standards for base:

BA15s - Single Contact Candelabra Bayonet (or S.C.Bayonet)

(not to scale)