

1129 is known as: 1129-USA

1129-USA bulb specifications:

category: **Miniature**

volt: **6.4**

amp: **2.62**

watt: **16.8**

base: **BA15s** - Single Contact Candelabra Bayonet (or S.C.Bayonet)

glass: **S8**

filament: **C6**

fil.res.: **2.44** ohm

i.lumens: **264**

cp: **21**

notes:

Automobile Lamp

backup

flasher lamp

Indicator Lamp

P21W

rear fog lamp

stop lamp

Stop light

turn signal lamp

uses socket: [DB-BA15S1](#)

1129-USA

also known as **Cross-Reference:**

1129-USA

031293401038

031293401038-EIKO

031293401700

031293401700-EIKO

031293440099

031293440099-EIKO

031293480149

031293480149-EIKO

050-525

050-525-LEITZ

1055-TUNGSRAM

1129

1129-317-BMC

1129-BMC

1129-BP

1129-BP-EIKO

1129-EIKO

1129-GE

1129-LECTRA

1129-LUGON

1129-MAZDA

1129-N

1129-NORMAN

1129-TUNG-SOL

1129-TUNGSOL

1129-WESTINGHOUSE

1129/317-BMC

1129N

2519

2519-FOCUS

317

317-1129-BMC

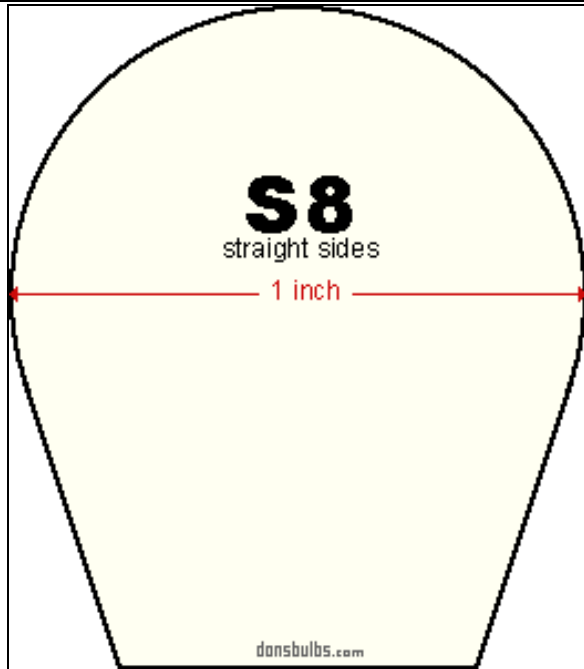

usual shape of **S8** glass envelopes (not to scale)

317-BMC
317-BTH
317-LUCAS
317-LUGON
317-MAZDA
317-OSRAM
317-USA
317/1129-BMC
4513
4513-STANLEY
6421-PHILIPS
6V21CP/BA15S
A-4513
A-4513-EIKO
A4513
A4513-EIKO
A4513BP-EIKO
AB2903
AS-3613
AS-3613-AIDLITE
AS3613
AS3613-AIDLITE
AS4603
E4-WD-1
E4-WD-1-FORD
E4WD1
E4WD1-FORD
FOCUS-2519
LUCAS-317
STANLEY-4513

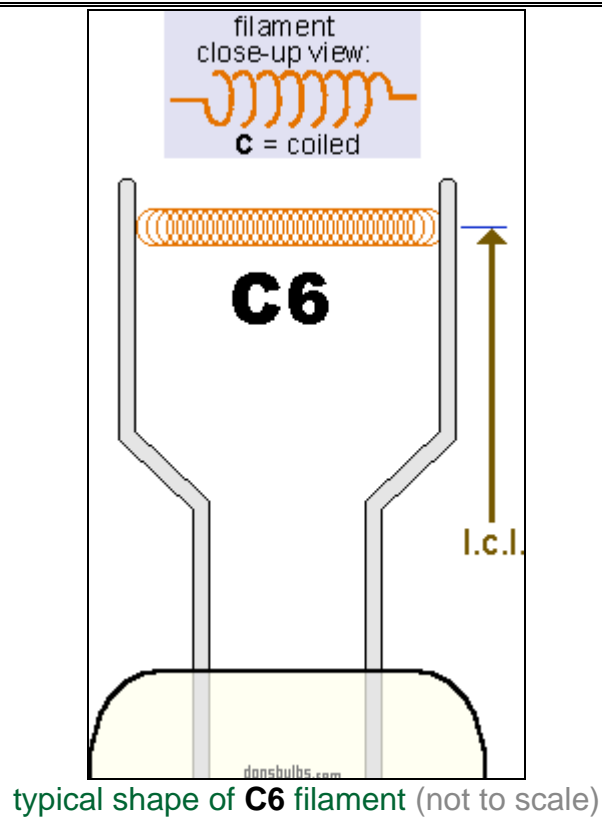

1129-USA

have been found in equipment:

Autocar

- 1942-6-VOLT-CONVENTIONAL DOME-LAMP Automobile / Truck
- 1946-6-VOLT DOME-LAMP Automobile / Truck
- 1947-6-VOLT DOME-LAMP Automobile / Truck
- 1948-6-VOLT DOME-LAMP Automobile / Truck
- 1949-6-VOLT DOME-LAMP Automobile / Truck
- 1950-6-VOLT DOME-LAMP Automobile / Truck
- 1952-DIESEL-6-VOLT STOP-LAMP Automobile / Truck

Available

- 1942 STOP-LAMP Automobile / Truck
- 1956-6-VOLT DIRECTION-LAMP Automobile / Truck

Baia Engineering Company

07200
1003 REVIEWER

Brockway

- 1947-6-VOLT DIRECTION-LAMP Automobile / Truck
- 1948-6-VOLT DIRECTION-LAMP Automobile / Truck
- 1949-6-VOLT DIRECTION-LAMP Automobile / Truck
- 1950-6-VOLT DIRECTION-LAMP Automobile / Truck
- 1951-6-VOLT DIRECTION-LAMP Automobile / Truck
- 1952-6-VOLT DIRECTION-LAMP Automobile / Truck
- 1953-6-VOLT DIRECTION-LAMP Automobile / Truck
- 1954-6-VOLT DIRECTION-LAMP Automobile / Truck
- 1955-6-VOLT DIRECTION-LAMP Automobile / Truck
- 1956-6-VOLT DIRECTION-LAMP Automobile / Truck
- 1957-6-VOLT DIRECTION-LAMP Automobile / Truck

Buick

- 1942 DIRECTION-SIGNAL-REAR Automobile
- 1946-SERIES-40 DIRECTION-SIGNAL-REAR Automobile
- 1947-SERIES-40 DIRECTION-SIGNAL-REAR Automobile
- 1948-SERIES-40 DIRECTION-SIGNAL-REAR Automobile
- 1949-SERIES-40 DIRECTION-SIGNAL-REAR Automobile
- 1950 DIRECTION-SIGNAL-REAR Automobile
- 1951-SERIES-40 DIRECTION-SIGNAL-REAR Automobile
- 1951-SERIES-50 DIRECTION-SIGNAL-REAR Automobile

BA15s B15s

single contact bayonet
SC bayonet

single contact candelabra bayonet

SCC (British single centre contact)

IEC7004-11A9
DIN49720

IEC7005-13
DIN49642T6

E
E25W
F
F15W
G
P
P21W
R
R5W
R10W
R18W
R21W
U
U45W

A18B
A18C
A18F
A18G
SCC
SC

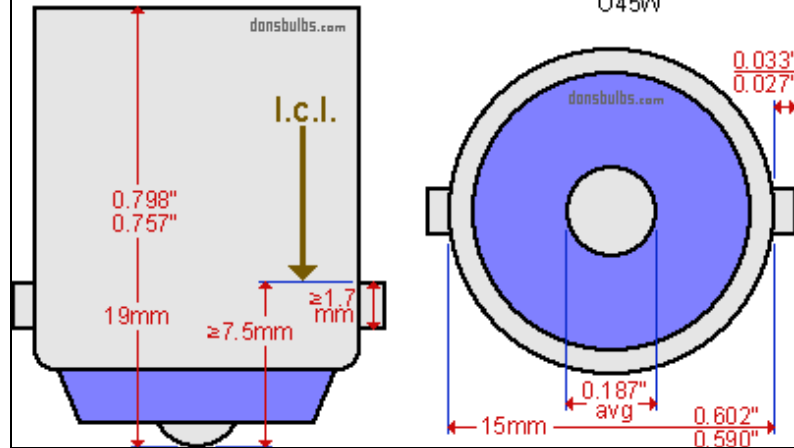

industry standards for base:

BA15s - Single Contact Candelabra Bayonet (or S.C.Bayonet)
(not to scale)

- 1951-SERIES-70 DIRECTION-SIGNAL-REAR Automobile
- 1952-SERIES-40 DIRECTION-SIGNAL-REAR Automobile
- 1952-SERIES-50 DIRECTION-SIGNAL-REAR Automobile
- 1952-SERIES-70 DIRECTION-SIGNAL-REAR Automobile
- 1953-SERIES-40 DIRECTION-SIGNAL-REAR Automobile

Checker Cab

- 1950 DIRECTION-LAMP Automobile / Truck
- 1951 DIRECTION-LAMP Automobile / Truck

Chevrolet

- 1947-1-TON DIRECTION-LAMP Automobile / Truck
- 1947-1/2-TON DIRECTION-LAMP Automobile / Truck
- 1947-1/2TON DIRECTION-LAMP Automobile / Truck
- 1947-1TON DIRECTION-LAMP Automobile / Truck
- 1948-1-TON DIRECTION-LAMP Automobile / Truck
- 1948-1/2-TON DIRECTION-LAMP Automobile / Truck
- 1948-1/2TON DIRECTION-LAMP Automobile / Truck
- 1948-1TON DIRECTION-LAMP Automobile / Truck
- 1949-1-TON DIRECTION-LAMP Automobile / Truck
- 1949-1/2-TON DIRECTION-LAMP Automobile / Truck
- 1949-1/2TON DIRECTION-LAMP Automobile / Truck
- 1949-1TON DIRECTION-LAMP Automobile / Truck
- 1949 DIRECTION-LAMP Automobile / Truck
- 1949 STOP-LAMP Automobile / Truck
- 1950-1-TON DIRECTION-LAMP Automobile / Truck
- 1950-1/2-TON DIRECTION-LAMP Automobile / Truck
- 1950-1/2TON DIRECTION-LAMP Automobile / Truck
- 1950-1TON DIRECTION-LAMP Automobile / Truck
- 1950 DIRECTION-LAMP Automobile / Truck
- 1950 STOP-LAMP Automobile / Truck
- 1951-1-TON DIRECTION-LAMP Automobile / Truck
- 1951-1/2-TON DIRECTION-LAMP Automobile / Truck
- 1951-1/2TON DIRECTION-LAMP Automobile / Truck
- 1951-1TON DIRECTION-LAMP Automobile / Truck
- 1951 DIRECTION-LAMP Automobile / Truck
- 1951 STOP-LAMP Automobile / Truck
- 1952-1-TON DIRECTION-LAMP Automobile / Truck
- 1952-1/2-TON DIRECTION-LAMP Automobile / Truck
- 1952-1/2TON DIRECTION-LAMP Automobile / Truck

1952-1TON DIRECTION-LAMP Automobile / Truck
1952 DIRECTION-LAMP Automobile / Truck
1952 STOP-LAMP Automobile / Truck
1953-1-1/2-TON DIRECTION-LAMP Automobile / Truck
1953-1-1/2TON DIRECTION-LAMP Automobile / Truck
1953-1-TON DIRECTION-LAMP Automobile / Truck
1953-1-TON STOP-LAMP Automobile / Truck
1953-1/2-TON DIRECTION-LAMP Automobile / Truck
1953-1/2-TON STOP-LAMP Automobile / Truck
1953-1/2TON DIRECTION-LAMP Automobile / Truck
1953-1/2TON STOP-LAMP Automobile / Truck
1953-1TON DIRECTION-LAMP Automobile / Truck
1953-1TON STOP-LAMP Automobile / Truck
1953-2-TON DIRECTION-LAMP Automobile / Truck
1953-2TON DIRECTION-LAMP Automobile / Truck
1953-3/4-TON DIRECTION-LAMP Automobile / Truck
1953-3/4-TON STOP-LAMP Automobile / Truck
1953-3/4TON DIRECTION-LAMP Automobile / Truck
1953-3/4TON STOP-LAMP Automobile / Truck
1953 STOP-LAMP Automobile
1954 DIRECTION-LAMP Automobile / Truck
1955 DIRECTION-LAMP Automobile / Truck

Chrysler

1941 STOP-LAMP Automobile
1942 STOP-LAMP Automobile
1946 STEP-COURTESY-LAMP Automobile
1946 STOP-LAMP Automobile
1947 STEP-COURTESY-LAMP Automobile
1947 STOP-LAMP Automobile
1948 STEP-COURTESY-LAMP Automobile
1948 STOP-LAMP Automobile
1949 STEP-COURTESY-LAMP Automobile
1949 STOP-LAMP Automobile
1950 STOP-LAMP Automobile
1953-C-56,58,66 BACK-UP-LAMP Automobile
1953-C56,58,66 BACK-UP-LAMP Automobile
1954-C-62,63,64 BACK-UP-LAMP Automobile
1954-C62,63,64 BACK-UP-LAMP Automobile

1955-6-VOLT-C-67,68,69 BACK-UP-LAMP Automobile
1955-6-VOLT-C67,68,69 BACK-UP-LAMP Automobile

Corbitt

1951-6-VOLT DOME-LAMP Automobile / Truck
1952-6-VOLT DOME-LAMP Automobile / Truck

Desoto

1941 STOP-LAMP Automobile
1942 STOP-LAMP Automobile
1946 STOP-LAMP Automobile
1947 STOP-LAMP Automobile
1948 STOP-LAMP Automobile
1949 STEP-COURTESY-LAMP Automobile
1949 STOP-LAMP Automobile
1950 STOP-LAMP Automobile
1953 BACK-UP-LAMP Automobile
1954 BACK-UP-LAMP Automobile
1955-6-VOLT BACK-UP-LAMP Automobile

Diamond T

1944-6-VOLT DIRECTION-LAMP Automobile / Truck
1945-6-VOLT DIRECTION-LAMP Automobile / Truck
1946-6-VOLT DIRECTION-LAMP Automobile / Truck
1947-6-VOLT DIRECTION-LAMP Automobile / Truck
1948-6-VOLT DIRECTION-LAMP Automobile / Truck
1949-6-VOLT DIRECTION-LAMP Automobile / Truck
1950-6-VOLT DIRECTION-LAMP Automobile / Truck
1951-6-VOLT DIRECTION-LAMP Automobile / Truck
1952-6-VOLT DIRECTION-LAMP Automobile / Truck
1953-6-VOLT DIRECTION-LAMP Automobile / Truck
1954-6-VOLT DIRECTION-LAMP Automobile / Truck
1955-6-VOLT DIRECTION-LAMP Automobile / Truck
1956-6-VOLT DIRECTION-LAMP Automobile / Truck
1957-6-VOLT DIRECTION-LAMP Automobile / Truck

Divco

1954 DIRECTION-LAMP Automobile / Truck
1955 DIRECTION-LAMP Automobile / Truck
1956 DIRECTION-LAMP Automobile / Truck
1957 DIRECTION-LAMP Automobile / Truck

Dodge

1941 STOP-LAMP Automobile / Truck
1942 STOP-LAMP Automobile / Truck
1946 STOP-LAMP Automobile / Truck
1947 STOP-LAMP Automobile / Truck
1948 STOP-LAMP Automobile / Truck
1949 STEP-COURTESY-LAMP Automobile
1949 STOP-LAMP Automobile / Truck
1950 DIRECTION-LAMP Automobile / Truck
1950 STOP-LAMP Automobile / Truck
1951 DIRECTION-LAMP Automobile / Truck
1952 DIRECTION-LAMP Automobile / Truck front:1158,rear:1129
1953 BACK-UP-LAMP Automobile
1953 DIRECTION-LAMP Automobile / Truck
1954 BACK-UP-LAMP Automobile
1954 DIRECTION-LAMP Automobile / Truck front:1129,rear:1154
1955-6-VOLT BACK-UP-LAMP Automobile
1955 DIRECTION-LAMP Automobile / Truck front:1129,rear:1154

Duplex

1950-6-VOLT DIRECTION-LAMP Automobile / Truck
1951-6-VOLT DIRECTION-LAMP Automobile / Truck
1952-6-VOLT DIRECTION-LAMP Automobile / Truck
1953-6-VOLT DIRECTION-LAMP Automobile / Truck
1954-6-VOLT DIRECTION-LAMP Automobile / Truck
1955-6-VOLT DIRECTION-LAMP Automobile / Truck

E.Leitz Incorporated

050-525 Microscope

050525 Microscope

Federal Manufacturing Engineering Corporation

1951-6-VOLT-STYLELINERS DOME-LAMP Automobile / Truck
1952-6-VOLT-STYLELINERS DOME-LAMP Automobile / Truck
1953-6-VOLT-STYLELINERS DOME-LAMP Automobile / Truck
1954-6-VOLT-STYLELINERS DOME-LAMP Automobile / Truck
1955-6-VOLT-STYLELINERS DOME-LAMP Automobile / Truck

Ford

1940 STOP-LAMP Automobile / Truck
1941 STOP-LAMP Automobile / Truck
1942 STOP-LAMP Automobile / Truck
1946 STOP-LAMP Automobile / Truck

1947 STOP-LAMP Automobile / Truck
1948-6-VOLT DIRECTION-LAMP Automobile / Truck
1949-6-VOLT DIRECTION-LAMP Automobile / Truck
1950-6-VOLT DIRECTION-LAMP Automobile / Truck
1951-6-VOLT DIRECTION-LAMP Automobile / Truck
1952-6-VOLT DIRECTION-LAMP Automobile / Truck
1953-PANEL,PARCEL-DELIVERY DIRECTION-LAMP Automobile /
Truck

1953 DIRECTION-LAMP Automobile / Truck
1954 DIRECTION-LAMP Automobile / Truck
1955-6-VOLT BACK-UP-LAMP Automobile
1955 DIRECTION-LAMP Automobile / Truck

Frazer

1947 DIRECTION-SIGNAL-REAR Automobile
1947 DOME-LAMP Automobile
1948 DIRECTION-SIGNAL-REAR Automobile
1948 DOME-LAMP Automobile
1949 DIRECTION-SIGNAL-REAR Automobile
1949 DOME-LAMP Automobile
1951 DOME-LAMP Automobile

FWD

1950-6-VOLT DIRECTION-LAMP Automobile / Truck
1951-6-VOLT DIRECTION-LAMP Automobile / Truck
1952-6-VOLT DIRECTION-LAMP Automobile / Truck
1953-6-VOLT DIRECTION-LAMP Automobile / Truck
1954-6-VOLT DIRECTION-LAMP Automobile / Truck

GMC

1949-FC,FF DIRECTION-LAMP Automobile / Truck
1949-FC,FF STOP-LAMP Automobile / Truck
1949-SOME-HC,ALL-HF DIRECTION-LAMP Automobile / Truck
1950-FC,FCS,FP,HCS-400,HCW-400 DIRECTION-
LAMP Automobile / Truck
1950-FC,FCS,FP,HCS-400,HCW-400 STOP-LAMP Automobile /
Truck
1950-FC,FCS,FP,HCS400,HCW400 DIRECTION-LAMP Automobile
/ Truck
1950-FC,FCS,FP,HCS400,HCW400 STOP-LAMP Automobile /
Truck

	1950-HC-450,470,HCS-450,HF-450,470,FF DIRECTION-LAMP Automobile / Truck
	1950-HC450,470,HCS450,HF450,470,FF DIRECTION-LAMP Automobile / Truck
	1950-SOME-HC,HCW,HF DIRECTION-LAMP Automobile / Truck
	1951-FC,FCS,FP,HCS-400,HCW-400 DIRECTION-LAMP Automobile / Truck
	1951-FC,FCS,FP,HCS-400,HCW-400 STOP-LAMP Automobile / Truck
	1951-FC,FCS,FP,HCS400,HCW400 DIRECTION-LAMP Automobile / Truck
	1951-FC,FCS,FP,HCS400,HCW400 STOP-LAMP Automobile / Truck
	1951-HC-450,470,HCS-450,HF-450,470,FF DIRECTION-LAMP Automobile / Truck
	1951-HC450,470,HCS450,HF450,470,FF DIRECTION-LAMP Automobile / Truck
	1951-SOME-HC,HCW,HF DIRECTION-LAMP Automobile / Truck
	1952-FC,FCS,FP,HCS-400,HCW-400 DIRECTION-LAMP Automobile / Truck
	1952-FC,FCS,FP,HCS-400,HCW-400 STOP-LAMP Automobile / Truck
	1952-FC,FCS,FP,HCS400,HCW400 DIRECTION-LAMP Automobile / Truck
	1952-FC,FCS,FP,HCS400,HCW400 STOP-LAMP Automobile / Truck
	1952-HC-450,470,HCS-450,HF-450,470,FF DIRECTION-LAMP Automobile / Truck
	1952-HC450,470,HCS450,HF450,470,FF DIRECTION-LAMP Automobile / Truck
	1952-SOME-HC,HCW,HF DIRECTION-LAMP Automobile / Truck
	1953-FC,FCS,FP,HCS-400,HCW-400 DIRECTION-LAMP Automobile / Truck
	1953-FC,FCS,FP,HCS-400,HCW-400 STOP-LAMP Automobile / Truck
	1953-FC,FCS,FP,HCS400,HCW400 DIRECTION-LAMP Automobile / Truck
	1953-FC,FCS,FP,HCS400,HCW400 STOP-LAMP Automobile /

Truck

1953-HC-450,470,HCS-450,HF-450,470,FF DIRECTION-LAMP Automobile / Truck

1953-HC450,470,HCS450,HF450,470,FF DIRECTION-LAMP Automobile / Truck

1953-SOME-HC,HCW,HF DIRECTION-LAMP Automobile / Truck
1954-6-VOLT DIRECTION-LAMP Automobile / Truck

Hahn

1942-6-VOLT DIRECTION-LAMP Automobile / Truck

1946-6-VOLT DIRECTION-LAMP Automobile / Truck

1947-6-VOLT DIRECTION-LAMP Automobile / Truck

1948-6-VOLT DIRECTION-LAMP Automobile / Truck

1949-6-VOLT DIRECTION-LAMP Automobile / Truck

1950-6-VOLT DIRECTION-LAMP Automobile / Truck

Hendrickson

1950-6-VOLT DOME-LAMP Automobile / Truck

1950-6-VOLT STOP-LAMP Automobile / Truck

1951-6-VOLT STOP-LAMP Automobile / Truck

1952-6-VOLT STOP-LAMP Automobile / Truck

1953-6-VOLT STOP-LAMP Automobile / Truck

1954-6-VOLT STOP-LAMP Automobile / Truck

1955-6-VOLT STOP-LAMP Automobile / Truck

1956-6-VOLT STOP-LAMP Automobile / Truck

Henry J

1953 BACK-UP-LAMP Automobile

1953 UNDER-HOOD-LAMP Automobile

Hudson

1948-COMMODORE DIRECTION-SIGNAL-REAR Automobile

1948-SUPER DIRECTION-SIGNAL-REAR Automobile

1949-COMMODORE DIRECTION-SIGNAL-REAR Automobile

1949-SUPER DIRECTION-SIGNAL-REAR Automobile

1950-COMMODORE DIRECTION-SIGNAL-REAR Automobile

1950-SUPER DIRECTION-SIGNAL-REAR Automobile

1951-COMMODORE DIRECTION-SIGNAL-REAR Automobile

1951-SUPER DIRECTION-SIGNAL-REAR Automobile

International

1949-6-VOLT DIRECTION-LAMP Automobile / Truck

1950-6-VOLT DIRECTION-LAMP Automobile / Truck
1951-6-VOLT DIRECTION-LAMP Automobile / Truck
1952-6-VOLT DIRECTION-LAMP Automobile / Truck
1953-6-VOLT DIRECTION-LAMP Automobile / Truck
1954-6-VOLT DIRECTION-LAMP Automobile / Truck
1955-6-VOLT DIRECTION-LAMP Automobile / Truck

Kaiser

1947-SPECIAL DOME-LAMP Automobile
1948-CUSTOM DIRECTION-SIGNAL-REAR Automobile
1948-CUSTOM DOME-LAMP Automobile
1948 DOME-LAMP Automobile
1949 DOME-LAMP Automobile
1953 TRUNK-COMPARTMENT-LAMP Automobile
1953 UNDER-HOOD-LAMP Automobile
1954 TRUNK-COMPARTMENT-LAMP Automobile
1954 UNDER-HOOD-LAMP Automobile

Lincoln Zephyr

1941-CONTINENTAL STOP-LAMP Automobile
1941-CUSTOM STOP-LAMP Automobile
1941 STOP-LAMP Automobile
1942 STOP-LAMP Automobile
1946 STOP-LAMP Automobile
1947 STOP-LAMP Automobile
1948 STOP-LAMP Automobile
1953 BACK-UP-LAMP Automobile
1954 BACK-UP-LAMP Automobile
1955-6-VOLT BACK-UP-LAMP Automobile

Mercury

1953 BACK-UP-LAMP Automobile
1954 BACK-UP-LAMP Automobile
1955-6-VOLT BACK-UP-LAMP Automobile

Nash

1942 STOP-LAMP Automobile
1946 STOP-LAMP Automobile
1947 STOP-LAMP Automobile
1948 STOP-LAMP Automobile
1949 DIRECTION-SIGNAL-FRONT Automobile
1949 DIRECTION-SIGNAL-REAR Automobile

1950 DIRECTION-SIGNAL-FRONT Automobile

1950 DIRECTION-SIGNAL-REAR Automobile

1951-RAMBLER DIRECTION-SIGNAL-REAR Automobile

1952-RAMBLER DIRECTION-SIGNAL-REAR Automobile

Oldsmobile

1950-SW-SERIES-76 DIRECTION-SIGNAL-REAR Automobile

1950-SW-SERIES-76 STOP-LAMP Automobile

1950-SW-SERIES-88 DIRECTION-SIGNAL-REAR Automobile

1950-SW-SERIES-88 STOP-LAMP Automobile

Packard

1948-DELUXE,SUPER,CUSTOM DIRECTION-SIGNAL-
REAR Automobile

1948-STANDARD DIRECTION-SIGNAL-REAR Automobile

1949-DELUXE,SUPER,CUSTOM DIRECTION-SIGNAL-
REAR Automobile

1949-STANDARD DIRECTION-SIGNAL-REAR Automobile

Plymouth

1941 STOP-LAMP Automobile

1942 STOP-LAMP Automobile

1946 STOP-LAMP Automobile

1947 STOP-LAMP Automobile

1948 STOP-LAMP Automobile

1949 STOP-LAMP Automobile

1950 STOP-LAMP Automobile

1953 BACK-UP-LAMP Automobile

1954 BACK-UP-LAMP Automobile

1955-6-VOLT BACK-UP-LAMP Automobile

Pontiac

1953 BACK-UP-LAMP Automobile

1954 BACK-UP-LAMP Automobile

Renault

PRE-1958 STOP-LAMP Automobile

REO

1952-6-VOLT DIRECTION-LAMP Automobile / Truck

1952-6-VOLT DOME-LAMP Automobile / Truck

1953-6-VOLT DIRECTION-LAMP Automobile / Truck

1954-6-VOLT DIRECTION-LAMP Automobile / Truck

1955-6-VOLT DIRECTION-LAMP Automobile / Truck
1956-6-VOLT DIRECTION-LAMP Automobile / Truck

Studebaker

1941 DIRECTION-LAMP Automobile / Truck
1942 DIRECTION-LAMP Automobile / Truck
1946 DIRECTION-LAMP Automobile / Truck
1947-COMMANDER DIRECTION-SIGNAL-REAR Automobile
1947 DIRECTION-LAMP Automobile / Truck
1947 DIRECTION-SIGNAL-FRONT Automobile / Truck
1947 DIRECTION-SIGNAL-REAR Automobile / Truck
1948-CHAMPION DIRECTION-SIGNAL-FRONT Automobile
1948-CHAMPION DIRECTION-SIGNAL-REAR Automobile
1948-COMMANDER DIRECTION-SIGNAL-REAR Automobile
1948 DIRECTION-LAMP Automobile / Truck
1949-CHAMPION DIRECTION-SIGNAL-FRONT Automobile
1949-CHAMPION DIRECTION-SIGNAL-REAR Automobile
1949-COMMANDER DIRECTION-SIGNAL-REAR Automobile
1949 DIRECTION-LAMP Automobile / Truck
1950 DIRECTION-LAMP Automobile / Truck
1950 DIRECTION-SIGNAL-REAR Automobile
1951 DIRECTION-LAMP Automobile / Truck
1952 DIRECTION-LAMP Automobile / Truck
1953 DIRECTION-LAMP Automobile / Truck
1954 BACK-UP-LAMP Automobile
1954 DIRECTION-LAMP Automobile / Truck
1955 DIRECTION-LAMP Automobile / Truck

White

1951-6-VOLT-3014,3016 DIRECTION-LAMP Automobile / Truck
1951-6-VOLT-WC-14,WC-26 DIRECTION-LAMP Automobile / Truck
1951-6-VOLT-WC-14,WC26 DIRECTION-LAMP Automobile / Truck
1951-6-VOLT-WC14,WC26 DIRECTION-LAMP Automobile / Truck
1952-6-VOLT-3014,3016 DIRECTION-LAMP Automobile / Truck
1952-6-VOLT-WC-14,WC-26 DIRECTION-LAMP Automobile / Truck
1952-6-VOLT-WC-14,WC26 DIRECTION-LAMP Automobile / Truck
1952-6-VOLT-WC14,WC26 DIRECTION-LAMP Automobile / Truck
1953-6-VOLT-3014,3016 DIRECTION-LAMP Automobile / Truck
1953-6-VOLT-WC-14,WC-26 DIRECTION-LAMP Automobile / Truck
1953-6-VOLT-WC-14,WC26 DIRECTION-LAMP Automobile / Truck

1953-6-VOLT-WC14,WC26 DIRECTION-LAMP Automobile / Truck
1954-6-VOLT-3014,3016 DIRECTION-LAMP Automobile / Truck
1954-6-VOLT-WC-14,WC-26 DIRECTION-LAMP Automobile / Truck
1954-6-VOLT-WC-14,WC26 DIRECTION-LAMP Automobile / Truck
1954-6-VOLT-WC14,WC26 DIRECTION-LAMP Automobile / Truck
1955-6-VOLT-3014,3016 DIRECTION-LAMP Automobile / Truck
1955-6-VOLT-WC-14,WC-26 DIRECTION-LAMP Automobile / Truck
1955-6-VOLT-WC-14,WC26 DIRECTION-LAMP Automobile / Truck
1955-6-VOLT-WC14,WC26 DIRECTION-LAMP Automobile / Truck
1956-6-VOLT-3014,3016 DIRECTION-LAMP Automobile / Truck
1956-6-VOLT-WC-14,WC-26 DIRECTION-LAMP Automobile / Truck
1956-6-VOLT-WC-14,WC26 DIRECTION-LAMP Automobile / Truck
1956-6-VOLT-WC14,WC26 DIRECTION-LAMP Automobile / Truck
1957-6-VOLT-3014,3016 DIRECTION-LAMP Automobile / Truck
1957-6-VOLT-WC-14,WC-26 DIRECTION-LAMP Automobile / Truck
1957-6-VOLT-WC-14,WC26 DIRECTION-LAMP Automobile / Truck
1957-6-VOLT-WC14,WC26 DIRECTION-LAMP Automobile / Truck

Willys

1952-CIV-JEEP REAR-LAMP Automobile
1952-CIV-JEEP STOP-LAMP Automobile
1952 DIRECTION-SIGNAL-REAR Automobile
1953-LARK,ACE,EAGLE DIRECTION-SIGNAL-REAR Automobile
1955-6-VOLT BACK-UP-LAMP Automobile
1955-JEEP DIRECTION-SIGNAL-REAR Automobile
1955-STATION-WAGON DIRECTION-SIGNAL-REAR Automobile
1955 DIRECTION-LAMP Automobile / Truck front:1158,rear:1129