

1130-USA

1130-USA bulb specifications:

category: **Miniature**
volt: **6.4**
amp: **2.62**
watt: **16.8**
base: **BA15d** - Double Contact Candelabra Bayonet (or D.C.Bayonet)
glass: **S8**
filament: **C6**
fil.res.: **2.44** ohm
m.o.l.: **2** inches
l.c.l.: **1.25** inches
burn pos: burn lamp in **ANY** position
i.lumens: **264**
cp: **21**
d.hours: **200**
notes:
Automobile Lamp
flasher lamp
stop lamp
uses socket: [DB-BA15D1](#)

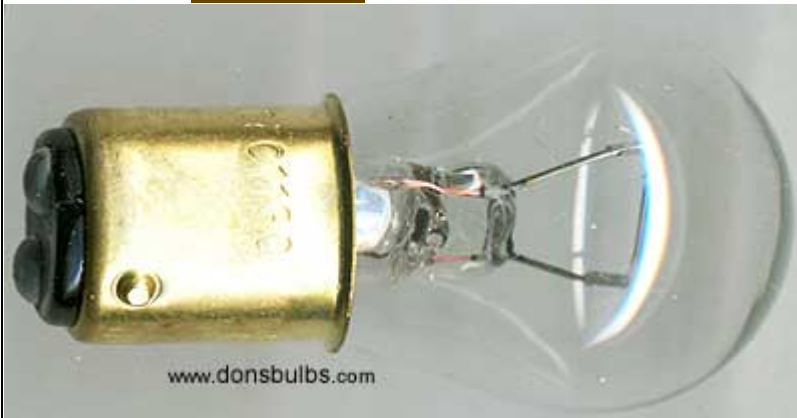

typical photo of **1130-USA** bulb type (your bulb may look slightly different)

1130-USA

also known as

Cross-Reference:

1130-USA
031293401724
031293401724-EIKO
1056-TUNGSRAM
1130
1130-CEC
1130-EIKO
1130-GE
1130-LECTRA
1130-LUGON
1130-MAZDA
1130CEC
2520-FOCUS
319-BMC
319-LUCAS
362-TRIFA
364-TRIFA
4514
4514-STANLEY
6.4-16.8-03
622500D-MICROLAMP
6422
AB3002
AGI-3424
AGI-AS846
AS-3614
AS-3614-AIDLITE
AS3614
AS3614-AIDLITE
AS4604
CEC-1130
CEC1130
CM1130
FOCUS-2520
LUCAS-319
STANLEY-4514

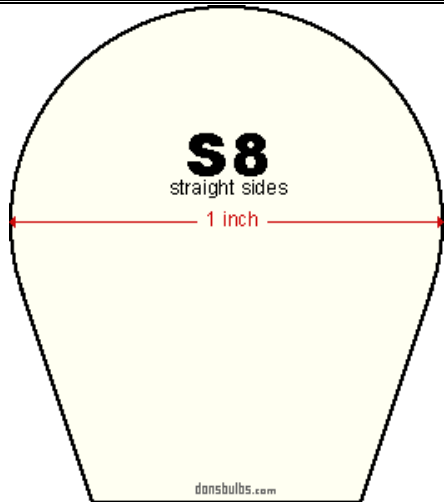

usual shape of **S8** glass envelopes (not to scale)

1130-USA

have been found in equipment:

Dodge

1955 STEP-COURTESY-LAMP Automobile

Hahn

1951 DOME-LAMP Automobile / Truck

1952 DOME-LAMP Automobile / Truck

1953 DOME-LAMP Automobile / Truck

1954 DOME-LAMP Automobile / Truck

1955 DOME-LAMP Automobile / Truck

Plymouth

1955 STEP-COURTESY-LAMP Automobile

BA15d

double contact bayonet

DC bayonet

double contact candelabra bayonet

SBC (British small bayonet cap)

IEC7004-11
DIN49721
IEC7005-13
DIN49642T6
A19A
A19B
A19C
A19D
B15d
SBC
DC
BD

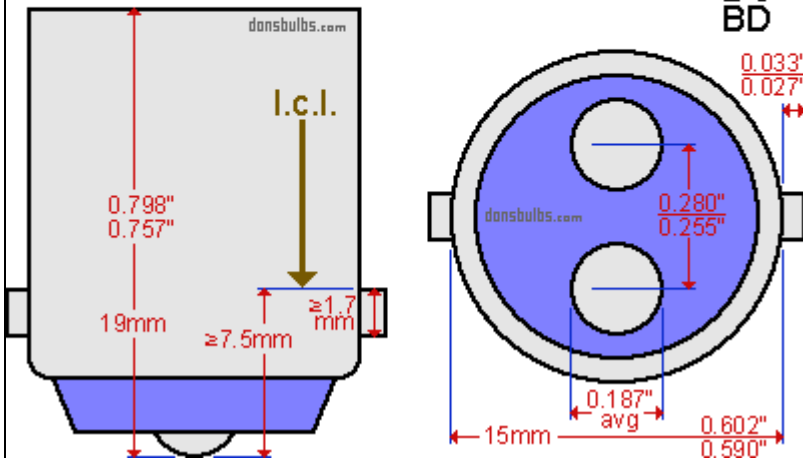

industry standards for base: **BA15d** - Double Contact Candelabra Bayonet (or D.C.Bayonet) (not to scale)

filament
close-up view:

C = coiled

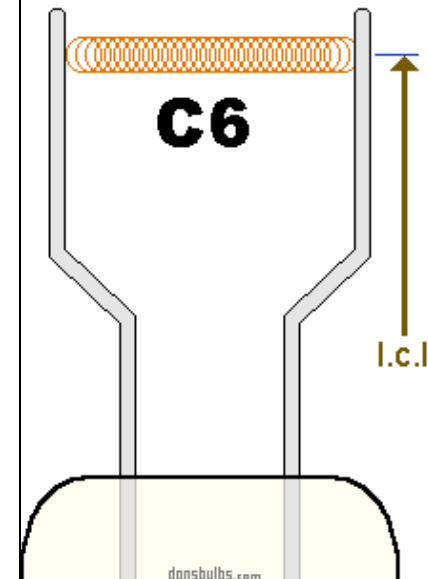

typical shape of **C6** filament (not to scale)