

# 1141 is known as: 1141-USA

## 1141-USA bulb specifications:

category: **Miniature**  
volt: **12.8**  
amp: **1.44**  
watt: **18.4**  
base: **BA15s** - Single Contact Candelabra Bayonet (or S.C.Bayonet)  
glass: **S8**  
filament: **C6**  
fil.res.: **8.89** ohm  
m.o.l.: **2** inches  
l.c.l.: **1.25** inches  
burn pos: burn lamp in **ANY** position  
i.lumens: **264**  
cp: **21**  
d.hours: **500**  
notes:  
**Aircraft Lamp**  
**Automotive Lamp**  
flasher lamp  
ground service lamp  
interior  
stop lamp  
turn signal lamp  
uses socket: [DB-BA15S1](#)

## 1141-USA also known as Cross-Reference:

1141-USA  
031293401113  
031293401113-EIKO  
031293401762  
031293401762-EIKO  
031293410665  
031293410665-EIKO  
1059-TUNGSRAM  
1141

## 1141-USA

have been found in equipment:

### Ahrens Fox

1945-VC,VR,YC,YR,EC,ER,FC-SPECIAL PARKING-LAMP Automobile / Truck  
1946-VC,VR,YC,YR,EC,ER,FC-SPECIAL PARKING-LAMP Automobile / Truck  
1947-VC,VR,YC,YR,EC,ER,FC-SPECIAL PARKING-LAMP Automobile / Truck  
1948-VC,VR,YC,YR,EC,ER,FC-SPECIAL PARKING-LAMP Automobile / Truck  
1949-VC,VR,YC,YR,EC,ER,FC-SPECIAL PARKING-LAMP Automobile / Truck  
1950-VC,VR,YC,YR,EC,ER,FC-SPECIAL PARKING-LAMP Automobile / Truck  
1951-VC,VR,YC,YR,EC,ER,FC-SPECIAL PARKING-LAMP Automobile / Truck  
1952-VC,YC,EC,FC-SPECIAL,HT,IT PARKING-LAMP Automobile / Truck

### American La France

1947-700-SERIES-12-VOLT PARKING-LAMP Automobile / Truck  
1947-700SERIES-12-VOLT PARKING-LAMP Automobile / Truck  
1948-700-SERIES-12-VOLT PARKING-LAMP Automobile / Truck  
1948-700SERIES-12-VOLT PARKING-LAMP Automobile / Truck  
1949-700-SERIES-12-VOLT PARKING-LAMP Automobile / Truck  
1949-700SERIES-12-VOLT PARKING-LAMP Automobile / Truck  
1950 PARKING-LAMP Automobile / Truck  
1951 PARKING-LAMP Automobile / Truck  
1952 PARKING-LAMP Automobile / Truck  
1953 PARKING-LAMP Automobile / Truck  
1954 PARKING-LAMP Automobile / Truck  
1955 PARKING-LAMP Automobile / Truck

1141-BMC  
1141-BP  
1141-BP-EIKO  
1141-BULK  
1141-BULK-EIKO  
1141-EIKO  
1141-GE  
1141-LECTRA  
1141-LUGON  
1141-MAZDA  
1141GE  
12.5-018-04  
12421  
1353-TRIFA  
20405-7  
221-BTH  
221-LUCAS  
221-MAZDA  
221-OSRAM  
22843-7  
2559  
2559-FOCUS  
26905  
35478-1141  
36377  
4523-STANLEY  
6240-00-155-7799  
7552-O  
7552-OS  
7552-OSRAM  
7983-OSRAM  
A4523  
AB2907  
AGI-3415  
AGI-AS816  
AS-3620  
AS-3620-AIDLITE  
AS3620

### **Autocar**

1945-12-VOLT DIRECTION-LAMP Automobile / Truck  
1945-12-VOLT DOME-LAMP Automobile / Truck  
1946-12-VOLT DIRECTION-LAMP Automobile / Truck  
1946-12-VOLT DOME-LAMP Automobile / Truck  
1947-12-VOLT DIRECTION-LAMP Automobile / Truck  
1947-12-VOLT DOME-LAMP Automobile / Truck  
1948-12-VOLT DIRECTION-LAMP Automobile / Truck  
1948-12-VOLT DOME-LAMP Automobile / Truck  
1949-12-VOLT DIRECTION-LAMP Automobile / Truck  
1949-12-VOLT DOME-LAMP Automobile / Truck  
1951-ALL-DIESEL-12-VOLT STOP-LAMP Automobile / Truck  
1952-DIESEL-12-VOLT STOP-LAMP Automobile / Truck  
1953 DOME-LAMP Automobile / Truck  
1954 DOME-LAMP Automobile / Truck  
1955-DIESEL DIRECTION-LAMP Automobile / Truck  
1955-GAS DIRECTION-LAMP Automobile / Truck

### **Available**

1956-12-VOLT DIRECTION-LAMP Automobile / Truck

### **Brockway**

1947-12-VOLT DIRECTION-LAMP Automobile / Truck  
1948-12-VOLT DIRECTION-LAMP Automobile / Truck  
1949-12-VOLT DIRECTION-LAMP Automobile / Truck  
1950-12-VOLT DIRECTION-LAMP Automobile / Truck  
1951-12-VOLT DIRECTION-LAMP Automobile / Truck  
1952-12-VOLT DIRECTION-LAMP Automobile / Truck  
1953-12-VOLT DIRECTION-LAMP Automobile / Truck  
1954-12-VOLT DIRECTION-LAMP Automobile / Truck  
1955-12-VOLT DIRECTION-LAMP Automobile / Truck  
1956-12-VOLT DIRECTION-LAMP Automobile / Truck  
1957-12-VOLT DIRECTION-LAMP Automobile / Truck

### **Chrysler**

1953-C-59 BACK-UP-LAMP Automobile  
1953-C59 BACK-UP-LAMP Automobile  
1954-1066 BACK-UP-LAMP Automobile  
1955-12-VOLT-C-70 BACK-UP-LAMP Automobile  
1955-12-VOLT-C70 BACK-UP-LAMP Automobile  
~~1956 BACK-UP-LAMP Automobile~~

AS3620-AIDLITE  
AS4610  
AT4404  
CM1141  
E39-NE2  
E39-NE2-FORD  
E39NE2  
E39NE2-FORD  
FOCUS-2559  
GE1141  
MB-11410  
MB-11430  
MB11410  
MB11430  
O-7552  
OS-7552  
STANLEY-4523

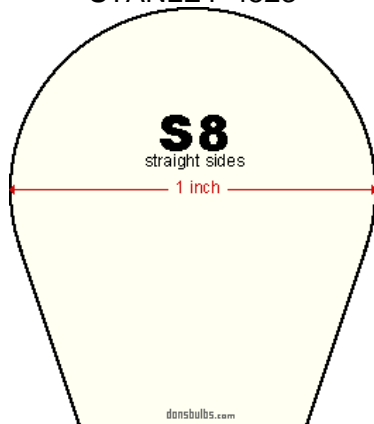

usual shape of **S8** glass envelopes (not to scale)

## Consul

PRE-1958-12-VOLT DIRECTION-SIGNAL-REAR Automobile

## Corbitt

1946-12-VOLT DIRECTION-LAMP Automobile / Truck  
1947-12-VOLT DIRECTION-LAMP Automobile / Truck  
1948-12-VOLT DIRECTION-LAMP Automobile / Truck  
1949-12-VOLT DIRECTION-LAMP Automobile / Truck  
1950-12-VOLT DIRECTION-LAMP Automobile / Truck  
1951-12-VOLT DIRECTION-LAMP Automobile / Truck  
1951-12-VOLT DOME-LAMP Automobile / Truck  
1952-12-VOLT DIRECTION-LAMP Automobile / Truck  
1952-12-VOLT DOME-LAMP Automobile / Truck  
1953 DIRECTION-LAMP Automobile / Truck  
1953 DOME-LAMP Automobile / Truck  
1954 DIRECTION-LAMP Automobile / Truck  
1954 DOME-LAMP Automobile / Truck  
1955 DIRECTION-LAMP Automobile / Truck  
1955 DOME-LAMP Automobile / Truck

## Desoto

1956-12-VOLT BACK-UP-LAMP Automobile

## Diamond T

1944-SERIES-910 DIRECTION-LAMP Automobile / Truck  
1945-SERIES-910 DIRECTION-LAMP Automobile / Truck  
1946-SERIES-910 DIRECTION-LAMP Automobile / Truck  
1947-12-VOLT DIRECTION-LAMP Automobile / Truck  
1948-12-VOLT DIRECTION-LAMP Automobile / Truck  
1949-12-VOLT DIRECTION-LAMP Automobile / Truck  
1950-12-VOLT DIRECTION-LAMP Automobile / Truck  
1951-12-VOLT DIRECTION-LAMP Automobile / Truck  
1952-12-VOLT DIRECTION-LAMP Automobile / Truck  
1953-12-VOLT DIRECTION-LAMP Automobile / Truck  
1954-12-VOLT DIRECTION-LAMP Automobile / Truck  
1955-12-VOLT DIRECTION-LAMP Automobile / Truck  
1956-12-VOLT DIRECTION-LAMP Automobile / Truck  
1957-12-VOLT DIRECTION-LAMP Automobile / Truck

## Dodge

1956-12-VOLT BACK-UP-LAMP Automobile

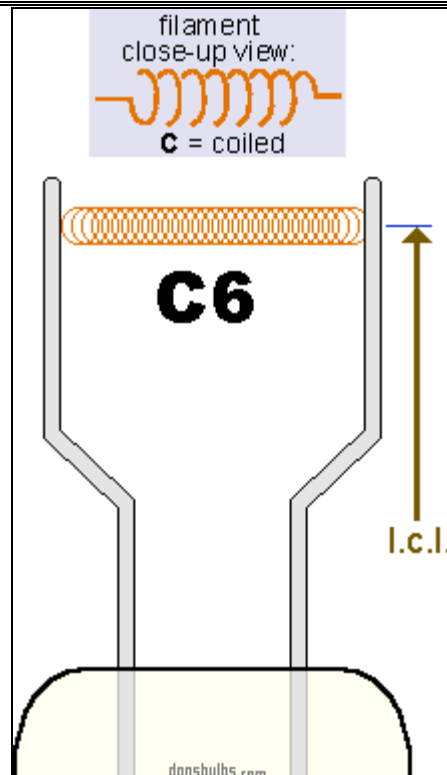

typical shape of **C6** filament (not to scale)

### Duplex

- 1949-12-VOLT DIRECTION-LAMP Automobile / Truck
- 1949-12-VOLT DOME-LAMP Automobile / Truck
- 1950-12-VOLT DIRECTION-LAMP Automobile / Truck
- 1950-12-VOLT DOME-LAMP Automobile / Truck
- 1951-12-VOLT DIRECTION-LAMP Automobile / Truck
- 1951-12-VOLT DOME-LAMP Automobile / Truck
- 1952-12-VOLT DIRECTION-LAMP Automobile / Truck
- 1952-12-VOLT DOME-LAMP Automobile / Truck
- 1953-12-VOLT DIRECTION-LAMP Automobile / Truck
- 1953-12-VOLT DOME-LAMP Automobile / Truck
- 1954-12-VOLT DIRECTION-LAMP Automobile / Truck
- 1954-12-VOLT DOME-LAMP Automobile / Truck
- 1955-12-VOLT DIRECTION-LAMP Automobile / Truck
- 1956-12-VOLT DIRECTION-LAMP Automobile / Truck

### Ford

- 1950-12-VOLT DIRECTION-LAMP Automobile / Truck
- 1950-12-VOLT DOME-LAMP Automobile / Truck
- 1950-12-VOLT STOP-LAMP Automobile / Truck
- 1951-12-VOLT DIRECTION-LAMP Automobile / Truck
- 1951-12-VOLT DOME-LAMP Automobile / Truck
- 1951-12-VOLT STOP-LAMP Automobile / Truck
- 1952-12-VOLT DOME-LAMP Automobile / Truck
- 1956-12-VOLT BACK-UP-LAMP Automobile
- 1956-12-VOLT DIRECTION-LAMP Automobile / Truck

### FWD

- 1950-12-VOLT DIRECTION-LAMP Automobile / Truck
- 1951-12-VOLT DIRECTION-LAMP Automobile / Truck
- 1952-12-VOLT DIRECTION-LAMP Automobile / Truck
- 1953-12-VOLT DIRECTION-LAMP Automobile / Truck
- 1954-12-VOLT DIRECTION-LAMP Automobile / Truck
- 1955 DIRECTION-LAMP Automobile / Truck
- 1956 DIRECTION-LAMP Automobile / Truck
- 1957 DIRECTION-LAMP Automobile / Truck

### GMC

- 1949-12-VOLT-HDC,HDF DIRECTION-LAMP Automobile / Truck
- 1950-12-VOLT-HDC,HDF DIRECTION-LAMP Automobile /

# BA15s B15s

single contact bayonet  
SC bayonet

single contact candelabra bayonet

SCC (British single centre contact)

IEC7004-11A9  
DIN49720

IEC7005-13  
DIN49642T6

IEE25W  
F15W  
PG  
P21W  
R5W  
R10W  
R18W  
R21W  
U  
U45W

A18B  
A18C  
A18F  
A18G  
SCC  
SC

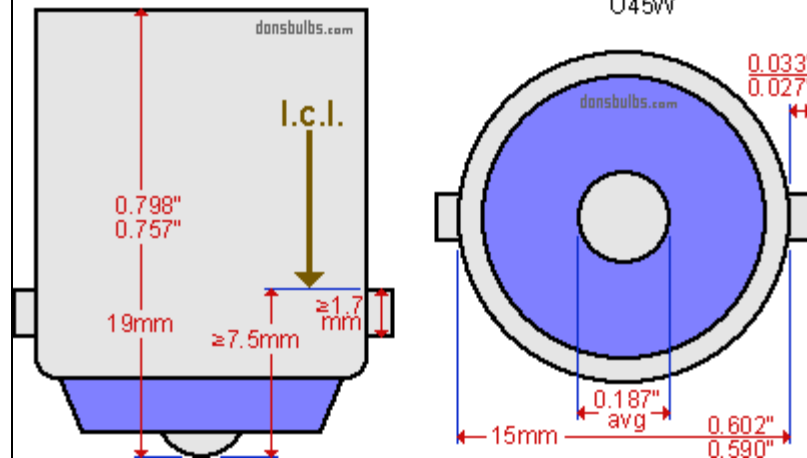

industry standards for base:

**BA15s** - Single Contact Candelabra Bayonet (or S.C.Bayonet)  
(not to scale)

- Truck
- 1951-12-VOLT-HDC,HDF DIRECTION-LAMP Automobile / Truck
- 1952-12-VOLT-HDC,HDF DIRECTION-LAMP Automobile / Truck
- 1953-12-VOLT-HDC,HDF DIRECTION-LAMP Automobile / Truck
- 1954-12-VOLT DIRECTION-LAMP Automobile / Truck
- 1957-12-VOLT STOP-LAMP Automobile / Truck

### Hendrickson

- 1950-12-VOLT DOME-LAMP Automobile / Truck
- 1950-12-VOLT STOP-LAMP Automobile / Truck

### International

- 1948-12-VOLT DIRECTION-LAMP Automobile / Truck
- 1949-12-VOLT DIRECTION-LAMP Automobile / Truck
- 1950-12-VOLT DIRECTION-LAMP Automobile / Truck
- 1951-12-VOLT DIRECTION-LAMP Automobile / Truck
- 1952-12-VOLT DIRECTION-LAMP Automobile / Truck
- 1953-12-VOLT DIRECTION-LAMP Automobile / Truck
- 1954-12-VOLT DIRECTION-LAMP Automobile / Truck
- 1955-12-VOLT DIRECTION-LAMP Automobile / Truck
- 1956-12-VOLT DIRECTION-LAMP Automobile / Truck
- 1957-12-VOLT DIRECTION-LAMP Automobile / Truck

### Lincoln Zephyr

- 1956-12-VOLT BACK-UP-LAMP Automobile
- 1957 BACK-UP-LAMP Automobile

### Mercury

- 1956-12-VOLT BACK-UP-LAMP Automobile
- 1957 BACK-UP-LAMP Automobile

### MG

- 1949 MIDGET TD Automobile Flasher direction indicators
- 1950 MIDGET TD Automobile Flasher direction indicators
- 1951 MIDGET TD Automobile Flasher direction indicators
- 1952 MIDGET TD Automobile Flasher direction indicators
- 1953 MIDGET TD Automobile Flasher direction indicators

### Nash

- 1955-METROPOLITAN DIRECTION-SIGNAL-REAR Automobile

**Oshkosh**

1949-12-VOLT DIRECTION-LAMP Automobile / Truck  
1950-12-VOLT DIRECTION-LAMP Automobile / Truck  
1951-12-VOLT DIRECTION-LAMP Automobile / Truck

**Plymouth**

1956-12-VOLT BACK-UP-LAMP Automobile

**REO**

1952-12-VOLT DIRECTION-LAMP Automobile / Truck  
1952-12-VOLT DOME-LAMP Automobile / Truck  
1953-12-VOLT DIRECTION-LAMP Automobile / Truck  
1954-12-VOLT DIRECTION-LAMP Automobile / Truck  
1955-12-VOLT DIRECTION-LAMP Automobile / Truck  
1956-12-VOLT DIRECTION-LAMP Automobile / Truck  
1957-12-VOLT DIRECTION-LAMP Automobile / Truck

**Seagrave**

1952-12-VOLT DIRECTION-LAMP Automobile / Truck  
1953 DIRECTION-LAMP Automobile / Truck front:1141,rear:93  
1954 DIRECTION-LAMP Automobile / Truck  
1954 STOP-LAMP Automobile / Truck  
1955 DIRECTION-LAMP Automobile / Truck front:1141,rear:93

**Walter Voss Incorporated**

1954 DIRECTION-LAMP Automobile / Truck  
1955 DIRECTION-LAMP Automobile / Truck

**Ward-La France**

1947-12-VOLT DIRECTION-LAMP Automobile / Truck  
1948-12-VOLT DIRECTION-LAMP Automobile / Truck  
1949-12-VOLT DIRECTION-LAMP Automobile / Truck  
1950-12-VOLT DIRECTION-LAMP Automobile / Truck  
1951-12-VOLT DIRECTION-LAMP Automobile / Truck  
1952-12-VOLT DIRECTION-LAMP Automobile / Truck  
1953-12-VOLT DIRECTION-LAMP Automobile / Truck  
1954-12-VOLT DIRECTION-LAMP Automobile / Truck  
1955-12-VOLT DIRECTION-LAMP Automobile / Truck  
1956-12-VOLT DIRECTION-LAMP Automobile / Truck  
1957-12-VOLT DIRECTION-LAMP Automobile / Truck

**Zephyr**

PRE-1958-12-VOLT DIRECTION-SIGNAL-REAR Automobile