

1176 is known as: 1176-USA www.donsbulbs.com

1176-USA bulb specifications:

category: **Miniature**
volt: **12.8 / 14**
amp: **1.34 / .59**
watt: **17.2 / 8.26**
base: **BA15d** - Double Contact Candelabra Bayonet (or D.C.Bayonet)
glass: **S8**
filament: **C6/C6**
fil.res.: **9.55 / 23.7** ohm
m.o.l.: **2** inches
l.c.l.: **1.25** inches
burn pos: burn lamp in **ANY** position
i.lumens: **264 / 75.4**
cp: **21 / 6**
d.hours: **200 / 1000**
notes:
Automobile Lamp
stop lamp
tail lamp
uses socket: [DB-BA15D1](#)

1176-USA also known as Cross-Reference:

1176-USA
031293402042
031293402042-EIKO
031293402059
031293402059-EIKO
1074-TUNGSRAM
1176
1176-BMC
1176-BP
1176-BP-EIKO
1176-EIKO
1176-GE
1176-LECTRA

1176-USA have been found in equipment:

Autocar

1942-12-VOLT-CABOVER-ENGINE STOP-LAMP Automobile / Truck
1942-12-VOLT-CABOVER-ENGINE TAIL-LAMP Automobile / Truck
1945-12-VOLT STOP-LAMP Automobile / Truck
1945-12-VOLT TAIL-LAMP Automobile / Truck
1946-12-VOLT STOP-LAMP Automobile / Truck
1946-12-VOLT TAIL-LAMP Automobile / Truck
1947-12-VOLT STOP-LAMP Automobile / Truck
1947-12-VOLT TAIL-LAMP Automobile / Truck
1948-12-VOLT STOP-LAMP Automobile / Truck
1948-12-VOLT TAIL-LAMP Automobile / Truck
1949-12-VOLT STOP-LAMP Automobile / Truck
1949-12-VOLT TAIL-LAMP Automobile / Truck
1950-12-VOLT-STANDARD STOP-LAMP Automobile / Truck
1950-12-VOLT-STANDARD TAIL-LAMP Automobile / Truck
1951-GAS-DRIVEN-12-VOLT STOP-LAMP Automobile / Truck
1951-GAS-DRIVEN-12-VOLT TAIL-LAMP Automobile / Truck
1952-GAS-12-VOLT STOP-LAMP Automobile / Truck
1952-GAS-12-VOLT TAIL-LAMP Automobile / Truck
1953 STOP-LAMP Automobile / Truck
1953 TAIL-LAMP Automobile / Truck
1954 STOP-LAMP Automobile / Truck
1954 TAIL-LAMP Automobile / Truck
1955-GAS STOP-LAMP Automobile / Truck
1955-GAS TAIL-LAMP Automobile / Truck

Available

1956-12-VOLT STOP-LAMP Automobile / Truck
1956-12-VOLT TAIL-LAMP Automobile / Truck

Brockway

1176-LUGON
1176-MAZDA
1176-TUNG-SOL
12415-PHILIPS
12503
12503-P
12503-PHILIPS
12503P
2351-TRIFA
2760
2760-FOCUS
33351
3351-TRIFA
4724
4724-STANLEY
625700U-MICROLAMP
7240-O
7240-OS
7240-OSRAM
7762-FOCUS
A4724B
AB3104
AB3105
AGI-3514
AGI-AS863
AS-3714
AS-3714-AIDLITE
AS-3715
AS-3715-AIDLITE
AS-3716
AS-3716-AIDLITE
AS3714
AS3714-AIDLITE
AS3715
AS3715-AIDLITE
AS3716
AS3716-AIDLITE
AS4704

1951-12-VOLT STOP-LAMP Automobile / Truck
1951-12-VOLT TAIL-LAMP Automobile / Truck
1952-12-VOLT STOP-LAMP Automobile / Truck
1952-12-VOLT TAIL-LAMP Automobile / Truck
1953-12-VOLT STOP-LAMP Automobile / Truck
1953-12-VOLT TAIL-LAMP Automobile / Truck
1954-12-VOLT STOP-LAMP Automobile / Truck
1954-12-VOLT TAIL-LAMP Automobile / Truck
1955-12-VOLT STOP-LAMP Automobile / Truck
1955-12-VOLT TAIL-LAMP Automobile / Truck
1956-12-VOLT STOP-LAMP Automobile / Truck
1956-12-VOLT TAIL-LAMP Automobile / Truck
1957-12-VOLT STOP-LAMP Automobile / Truck
1957-12-VOLT TAIL-LAMP Automobile / Truck

Diamond T

1944-SERIES-910 STOP-LAMP Automobile / Truck
1944-SERIES-910 TAIL-LAMP Automobile / Truck
1945-SERIES-910 STOP-LAMP Automobile / Truck
1945-SERIES-910 TAIL-LAMP Automobile / Truck
1946-SERIES-910 STOP-LAMP Automobile / Truck
1946-SERIES-910 TAIL-LAMP Automobile / Truck
1947-12-VOLT STOP-LAMP Automobile / Truck
1947-12-VOLT TAIL-LAMP Automobile / Truck
1948-12-VOLT STOP-LAMP Automobile / Truck
1948-12-VOLT TAIL-LAMP Automobile / Truck
1949-12-VOLT STOP-LAMP Automobile / Truck
1949-12-VOLT TAIL-LAMP Automobile / Truck
1950-12-VOLT STOP-LAMP Automobile / Truck
1950-12-VOLT TAIL-LAMP Automobile / Truck
1951-12-VOLT STOP-LAMP Automobile / Truck
1951-12-VOLT TAIL-LAMP Automobile / Truck
1952-12-VOLT STOP-LAMP Automobile / Truck
1952-12-VOLT TAIL-LAMP Automobile / Truck
1953-12-VOLT STOP-LAMP Automobile / Truck
1953-12-VOLT TAIL-LAMP Automobile / Truck
1954-12-VOLT STOP-LAMP Automobile / Truck
1954-12-VOLT TAIL-LAMP Automobile / Truck
1955-12-VOLT STOP-LAMP Automobile / Truck

AS4705
CM1176
FOCUS-2760
MB-11760
MB11760
O-7240
OS-7240
OS7240
P-12503
P12503
STANLEY-4724

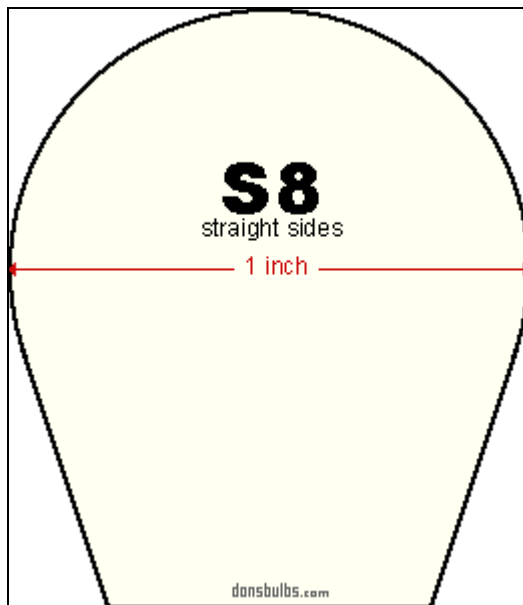

usual shape of **S8** glass envelopes (not to scale)

1955-12-VOLT TAIL-LAMP Automobile / Truck
1956-12-VOLT STOP-LAMP Automobile / Truck
1956-12-VOLT TAIL-LAMP Automobile / Truck
1957-12-VOLT STOP-LAMP Automobile / Truck
1957-12-VOLT TAIL-LAMP Automobile / Truck

Duplex

1949-12-VOLT STOP-LAMP Automobile / Truck
1949-12-VOLT TAIL-LAMP Automobile / Truck
1950-12-VOLT STOP-LAMP Automobile / Truck
1950-12-VOLT TAIL-LAMP Automobile / Truck
1951-12-VOLT STOP-LAMP Automobile / Truck
1951-12-VOLT TAIL-LAMP Automobile / Truck
1952-12-VOLT STOP-LAMP Automobile / Truck
1952-12-VOLT TAIL-LAMP Automobile / Truck
1953-12-VOLT STOP-LAMP Automobile / Truck
1953-12-VOLT TAIL-LAMP Automobile / Truck
1954-12-VOLT STOP-LAMP Automobile / Truck
1954-12-VOLT TAIL-LAMP Automobile / Truck
1955-12-VOLT STOP-LAMP Automobile / Truck
1955-12-VOLT TAIL-LAMP Automobile / Truck
1956-12-VOLT STOP-LAMP Automobile / Truck
1956-12-VOLT TAIL-LAMP Automobile / Truck

Federal Manufacturing Engineering Corporation

1942-12-VOLT STOP-LAMP Automobile / Truck
1942-12-VOLT TAIL-LAMP Automobile / Truck
1944-12-VOLT STOP-LAMP Automobile / Truck
1944-12-VOLT TAIL-LAMP Automobile / Truck
1945-12-VOLT STOP-LAMP Automobile / Truck
1945-12-VOLT TAIL-LAMP Automobile / Truck
1946-12-VOLT STOP-LAMP Automobile / Truck
1946-12-VOLT TAIL-LAMP Automobile / Truck
1947-12-VOLT STOP-LAMP Automobile / Truck
1947-12-VOLT TAIL-LAMP Automobile / Truck
1948-12-VOLT STOP-LAMP Automobile / Truck
1948-12-VOLT TAIL-LAMP Automobile / Truck
1949-12-VOLT STOP-LAMP Automobile / Truck
1949-12-VOLT TAIL-LAMP Automobile / Truck
1950-12-VOLT STOP-LAMP Automobile / Truck

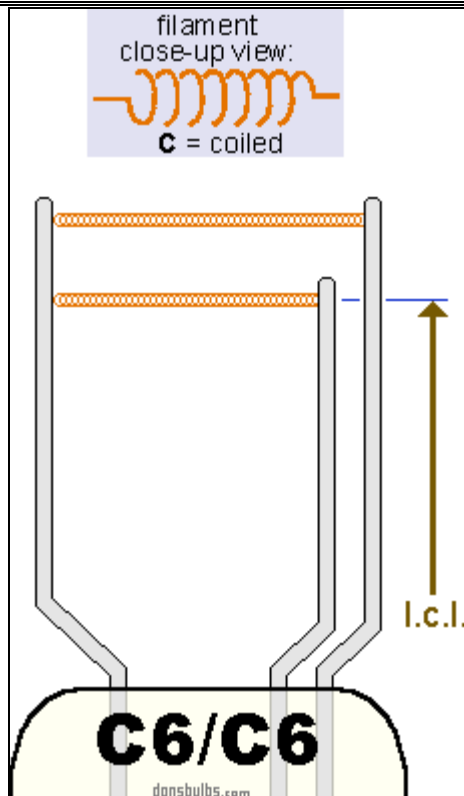

typical shape of C6/C6 filament (not to scale)

1950-12-VOLT TAIL-LAMP Automobile / Truck
 1951-12-VOLT STOP-LAMP Automobile / Truck
 1951-12-VOLT TAIL-LAMP Automobile / Truck
 1952-12-VOLT STOP-LAMP Automobile / Truck
 1952-12-VOLT TAIL-LAMP Automobile / Truck
 1953-12-VOLT STOP-LAMP Automobile / Truck
 1953-12-VOLT TAIL-LAMP Automobile / Truck
 1954-12-VOLT STOP-LAMP Automobile / Truck
 1954-12-VOLT TAIL-LAMP Automobile / Truck
 1955-12-VOLT STOP-LAMP Automobile / Truck
 1955-12-VOLT TAIL-LAMP Automobile / Truck

FWD

1950-12-VOLT STOP-LAMP Automobile / Truck
 1950-12-VOLT TAIL-LAMP Automobile / Truck
 1951-12-VOLT STOP-LAMP Automobile / Truck
 1951-12-VOLT TAIL-LAMP Automobile / Truck
 1952-12-VOLT STOP-LAMP Automobile / Truck
 1952-12-VOLT TAIL-LAMP Automobile / Truck
 1953-12-VOLT STOP-LAMP Automobile / Truck
 1953-12-VOLT TAIL-LAMP Automobile / Truck
 1954-12-VOLT STOP-LAMP Automobile / Truck
 1954-12-VOLT TAIL-LAMP Automobile / Truck

Hendrickson

1951-12-VOLT DIRECTION-LAMP Automobile / Truck
 1952-12-VOLT DIRECTION-LAMP Automobile / Truck
 1953-12-VOLT DIRECTION-LAMP Automobile / Truck
 1954-12-VOLT DIRECTION-LAMP Automobile / Truck
 1955-12-VOLT DIRECTION-LAMP Automobile / Truck
 1956-12-VOLT DIRECTION-LAMP Automobile / Truck

International

1942-12-VOLT STOP-LAMP Automobile / Truck
 1942-12-VOLT TAIL-LAMP Automobile / Truck
 1946-12-VOLT STOP-LAMP Automobile / Truck
 1946-12-VOLT TAIL-LAMP Automobile / Truck
 1947-12-VOLT STOP-LAMP Automobile / Truck
 1947-12-VOLT TAIL-LAMP Automobile / Truck
 1948-12-VOLT STOP-LAMP Automobile / Truck
 1948-12-VOLT TAIL-LAMP Automobile / Truck

BA15d

double contact bayonet

DC bayonet

double contact candelabra bayonet

SBC (British small bayonet cap)

IEC7004-11
DIN49721

IEC7005-13
DIN49642T6

A19A
A19B
A19C
A19D
B15d
SBC
DC
BD

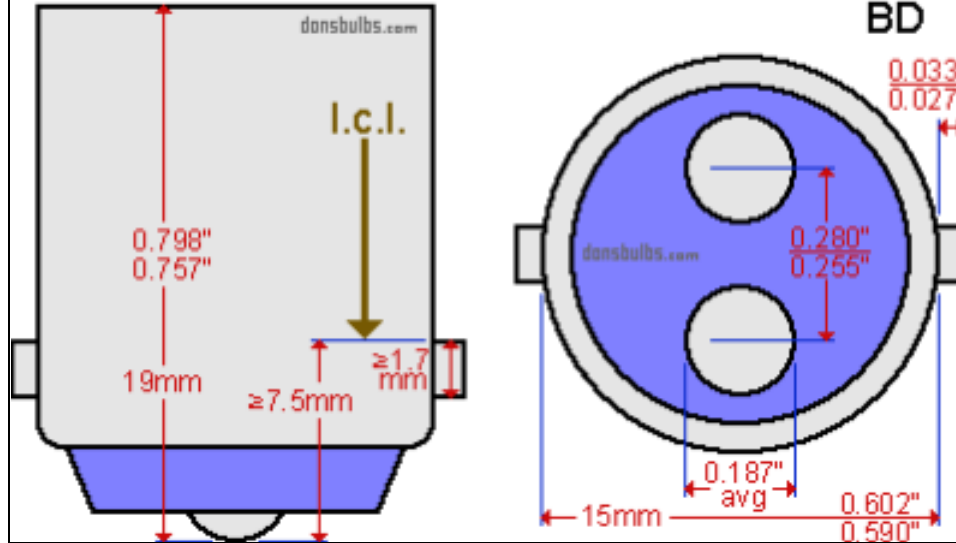

industry standards for base:

BA15d - Double Contact Candelabra Bayonet (or D.C.Bayonet)
(not to scale)

- 1949-12-VOLT STOP-LAMP Automobile / Truck
- 1949-12-VOLT TAIL-LAMP Automobile / Truck
- 1950-12-VOLT STOP-LAMP Automobile / Truck
- 1950-12-VOLT TAIL-LAMP Automobile / Truck
- 1951-12-VOLT STOP-LAMP Automobile / Truck
- 1951-12-VOLT TAIL-LAMP Automobile / Truck
- 1952-12-VOLT STOP-LAMP Automobile / Truck
- 1952-12-VOLT TAIL-LAMP Automobile / Truck
- 1953-12-VOLT STOP-LAMP Automobile / Truck
- 1953-12-VOLT TAIL-LAMP Automobile / Truck
- 1954-12-VOLT STOP-LAMP Automobile / Truck
- 1954-12-VOLT TAIL-LAMP Automobile / Truck
- 1955-12-VOLT STOP-LAMP Automobile / Truck
- 1955-12-VOLT TAIL-LAMP Automobile / Truck
- 1956-12-VOLT STOP-LAMP Automobile / Truck
- 1956-12-VOLT TAIL-LAMP Automobile / Truck
- 1957-12-VOLT STOP-LAMP Automobile / Truck
- 1957-12-VOLT TAIL-LAMP Automobile / Truck

Morris

- PRE-1958-12-VOLT REAR-LAMP Automobile
- PRE-1958-12-VOLT STOP-LAMP Automobile

REO

- 1946-12-VOLT STOP-LAMP Automobile / Truck
- 1946-12-VOLT TAIL-LAMP Automobile / Truck
- 1947-12-VOLT STOP-LAMP Automobile / Truck
- 1947-12-VOLT TAIL-LAMP Automobile / Truck
- 1948-12-VOLT STOP-LAMP Automobile / Truck
- 1948-12-VOLT TAIL-LAMP Automobile / Truck
- 1949-12-VOLT STOP-LAMP Automobile / Truck
- 1949-12-VOLT TAIL-LAMP Automobile / Truck
- 1950-12-VOLT STOP-LAMP Automobile / Truck
- 1950-12-VOLT TAIL-LAMP Automobile / Truck
- 1951-12-VOLT STOP-LAMP Automobile / Truck
- 1951-12-VOLT TAIL-LAMP Automobile / Truck
- 1952-12-VOLT STOP-LAMP Automobile / Truck
- 1952-12-VOLT TAIL-LAMP Automobile / Truck
- 1953-12-VOLT STOP-LAMP Automobile / Truck
- 1953-12-VOLT TAIL-LAMP Automobile / Truck

Rover

PRE-1958-12-VOLT DIRECTION-SIGNAL-
FRONT Automobile

PRE-1958-12-VOLT PARKING-LAMP Automobile

White

1942-12-VOLT-WA STOP-LAMP Automobile / Truck

1942-12-VOLT-WA TAIL-LAMP Automobile / Truck

1946-12-VOLT-WA STOP-LAMP Automobile / Truck

1946-12-VOLT-WA TAIL-LAMP Automobile / Truck

1946-12-VOLT-WB STOP-LAMP Automobile / Truck

1946-12-VOLT-WB TAIL-LAMP Automobile / Truck

1947-12-VOLT-WA STOP-LAMP Automobile / Truck

1947-12-VOLT-WA TAIL-LAMP Automobile / Truck

1947-12-VOLT-WB STOP-LAMP Automobile / Truck

1947-12-VOLT-WB TAIL-LAMP Automobile / Truck

1948-12-VOLT-WB STOP-LAMP Automobile / Truck

1948-12-VOLT-WB TAIL-LAMP Automobile / Truck

1949-12-VOLT STOP-LAMP Automobile / Truck

1949-12-VOLT TAIL-LAMP Automobile / Truck

1950-12-VOLT-WC-28-TOWC-32 STOP-LAMP Automobile /
Truck

1950-12-VOLT-WC-28-TOWC-32 TAIL-LAMP Automobile / Truck

1950-12-VOLT-WC28TOWC32 STOP-LAMP Automobile / Truck

1950-12-VOLT-WC28TOWC32 TAIL-LAMP Automobile / Truck

1951-12-VOLT STOP-LAMP Automobile / Truck

1951-12-VOLT TAIL-LAMP Automobile / Truck

1952-12-VOLT STOP-LAMP Automobile / Truck

1952-12-VOLT TAIL-LAMP Automobile / Truck

1953-12-VOLT STOP-LAMP Automobile / Truck

1953-12-VOLT TAIL-LAMP Automobile / Truck

1954-12-VOLT STOP-LAMP Automobile / Truck

1954-12-VOLT TAIL-LAMP Automobile / Truck

1955-12-VOLT STOP-LAMP Automobile / Truck

1955-12-VOLT TAIL-LAMP Automobile / Truck

1956-12-VOLT STOP-LAMP Automobile / Truck

1956-12-VOLT TAIL-LAMP Automobile / Truck

1957-12-VOLT STOP-LAMP Automobile / Truck

1957-12-VOLT TAIL-LAMP Automobile / Truck