

210is known as: 210-USA

210-USA bulb specifications:

category: **Miniature**

volt: **6.5**

amp: **1.78**

watt: **11.6**

base: **BA15d** - Double Contact Candelabra Bayonet (or D.C.Bayonet)

glass: **B6**

filament: **C6**

fil.res.: **3.65** ohm

m.o.l.: **1.75** inches

l.c.l.: **1.06** inches

i.lumens: **189**

cp: **15**

d.hours: **100**

notes:

Instrument Lamp

uses socket: [DB-BA15D1](#)

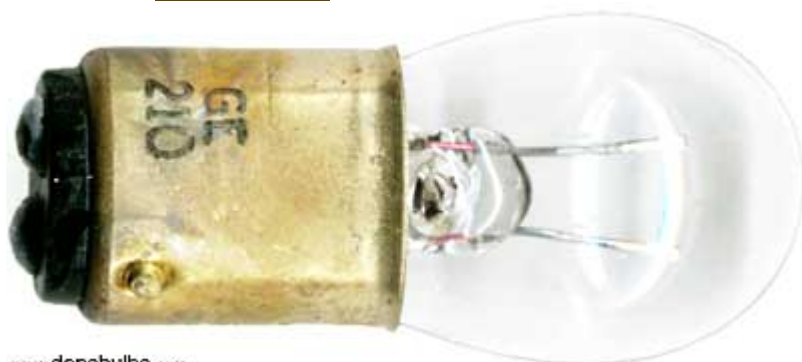

www.donsbulbs.com

typical photo of **210-USA** bulb type
(your bulb may look slightly different)

210-USA

also known as **Cross-Reference:**

210-USA

031293404541

031293404541-EIKO

210

210-EIKO

210-GE

210-N

210-NORMAN

210-WESTINGHOUSE

210GE

210N

2218

2218-FOCUS

365T

365T-AO

3662 [alternate 2]

3662-STANLEY

6.5-012-03

6V

AB2801

AGI-3313

AO-365T

AO365T

AT-3312

AT-3312-AIDLITE

AT3312

AT3312-AIDLITE

AT4302

CM210

FOCUS-2218

GE210

STANLEY-3662

210-USA

have been found in equipment:

Buick

1953-SERIES-40 DOME-LAMP Automobile

Chrysler

1954 DOME-LAMP Automobile

1954 STEP-COURTESY-LAMP Automobile

1955-6-VOLT-C-67,68,69 MAP-LAMP Automobile

1955-6-VOLT-C67,68,69 MAP-LAMP Automobile

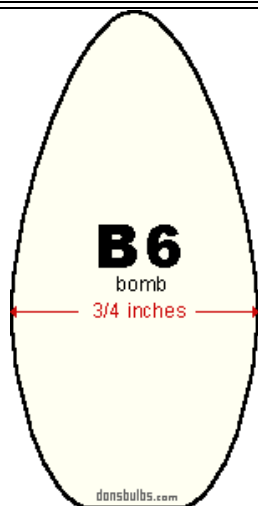

usual shape of **B6** glass envelopes (not to scale)

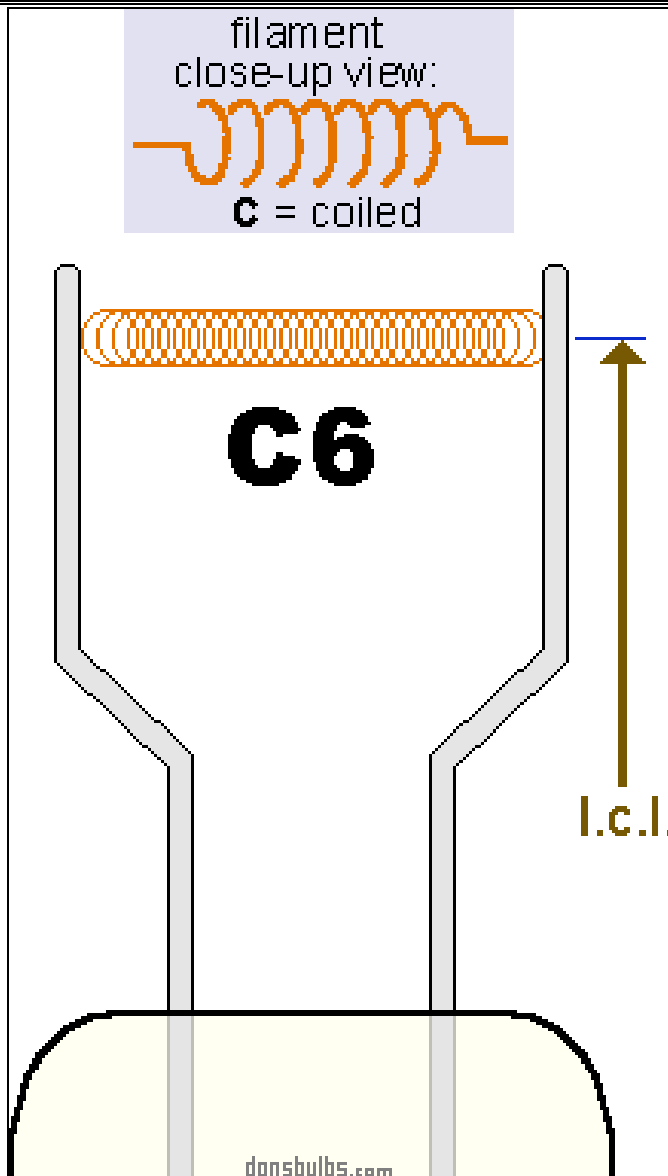

typical shape of C6 filament (not to scale)

- 1955 DOME-LAMP Automobile
- 1955 STEP-COURTESY-LAMP Automobile
- Desoto**
- 1954 STEP-COURTESY-LAMP Automobile
- 1955-6-VOLT MAP-LAMP Automobile
- 1955 DOME-LAMP Automobile
- 1955 STEP-COURTESY-LAMP Automobile
- Dodge**
- 1954 STEP-COURTESY-LAMP Automobile
- 1955-6-VOLT MAP-LAMP Automobile
- 1955 DOME-LAMP Automobile / Truck
- Lincoln Zephyr**
- 1951 DOME-LAMP Automobile
- Packard**
- 1952 DOME-LAMP Automobile
- 1953-2601,2611,2631 DOME-LAMP Automobile
- 1953-2602,2606,2626 DOME-LAMP Automobile
- 1954 DOME-LAMP Automobile
- Plymouth**
- 1954 STEP-COURTESY-LAMP Automobile
- 1955 DOME-LAMP Automobile
- Pontiac**
- 1953-DELUXE DOME-LAMP Automobile
- 1953-SPECIAL DOME-LAMP Automobile
- Studebaker**
- 1953 BRAKE-SIGNAL-LAMP Automobile
- 1954 BRAKE-SIGNAL-LAMP Automobile
- 1955-6-VOLT BRAKE-SIGNAL-LAMP Automobile

BA15d

double contact bayonet

DC bayonet

double contact candelabra bayonet

SBC (British small bayonet cap)

IEC7004-11

DIN49721

IEC7005-13

DIN49642T6

A19A

A19B

A19C

A19D

B15d

SBC

DC

BD

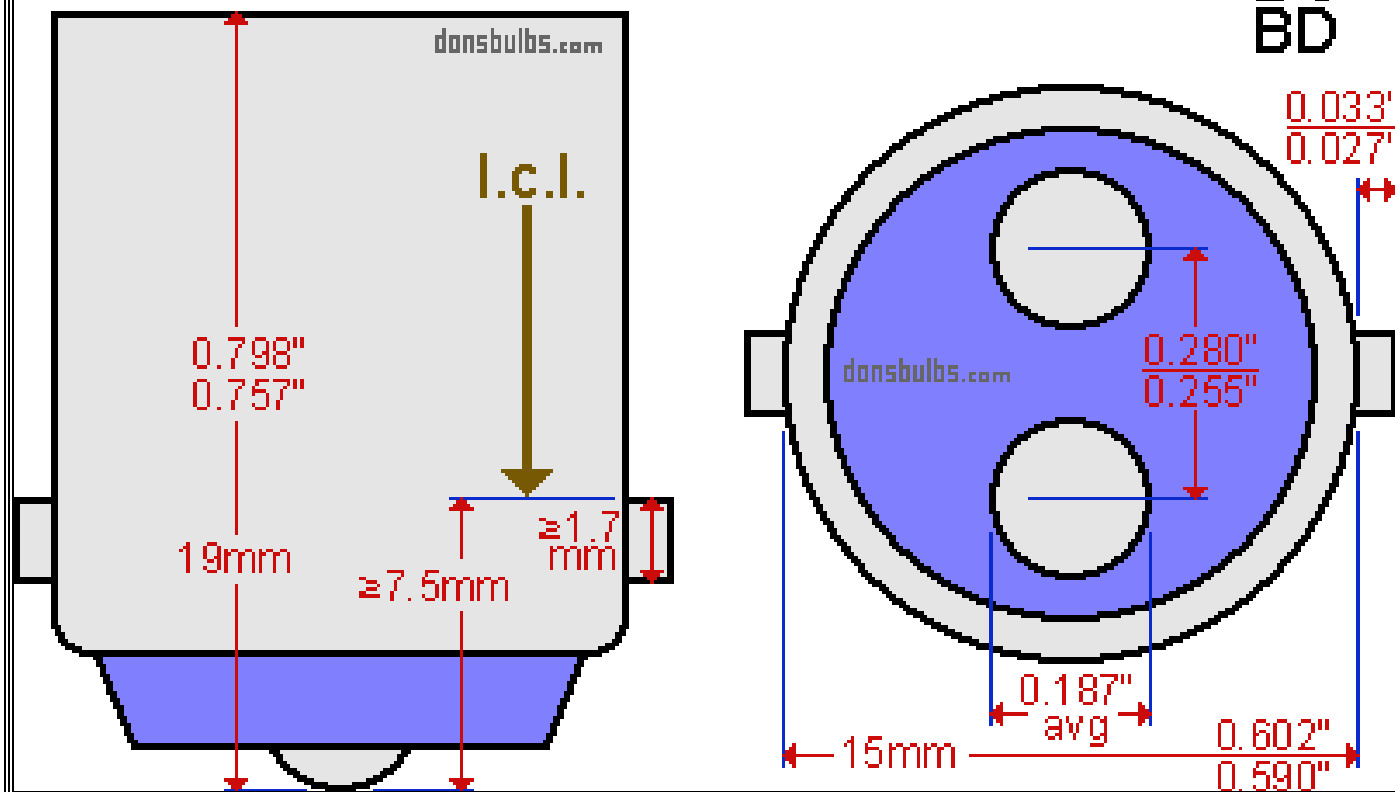

industry standards for base: BA15d - Double Contact Candelabra Bayonet (or D.C.Bayonet) (not to scale)