

82 is known as: 82-USA

82-USA bulb specifications:

category: **Miniature**

volt: **6.5**

amp: **1.02**

watt: **6.63**

base: **BA15d** - Double Contact Candelabra Bayonet (or D.C.Bayonet)

glass: **G6**

filament: **C2R**

fil.res.: **6.37** ohm

m.o.l.: **1.44** inches

l.c.l.: **.75** inches

i.lumens: **75.4**

cp: **6**

d.hours: **500**

notes:

Automotive Lamp

Marine

side lamp

tail lamp

uses socket: [DB-BA15D1](#)

82-USA also known as

Cross-Reference:

82-USA

031293409645

031293409645-EIKO

11-167

20/82-MAZDA

2012

2012-FOCUS

2012-HALCO

2012-S

2012-S-MARCO

2012S

2012S-MARCO

206

206-82-MAZDA

206-BMC

206-BTH

206-LUCAS

206-MAZDA

206-OSRAM

206-PHILIPS

206-USA

2614-TUNGSRAM

312-TRIFA

4114

4114-STANLEY

6.5-007-03

606100U-MICROLAMP

82

82-206

82-206-MAZDA

82-206-USA

82-EIKO

82-GE

82-LECTRA
82-LUGON
82-MAZDA
82-WESTINGHOUSE
82/206-MAZDA
AB2502
AT-3114
AT-3114-AIDLITE
AT3114
AT3114-AIDLITE
AT4104
CM82
EFC25
EFC25-HALCO
FOCUS-2012
LUCAS-206
MB-00820
MB00820
STANLEY-4114

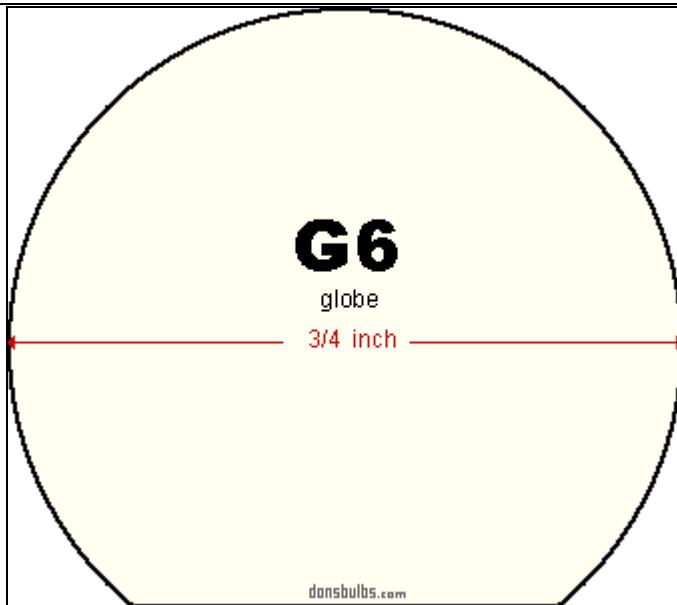

usual shape of G6 glass envelopes (not to scale)

82-USA have been found in equipment:

Buick

- 1941 DOME-LAMP Automobile
- 1946-SERIES-40 DOME-LAMP Automobile
- 1946-SERIES-40 STEP-COURTESY-LAMP Automobile
- 1946-SERIES-50 DOME-LAMP Automobile
- 1946-SERIES-50 STEP-COURTESY-LAMP Automobile
- 1946-SERIES-70 DOME-LAMP Automobile
- 1946-SERIES-70 STEP-COURTESY-LAMP Automobile
- 1947-SERIES-40 DOME-LAMP Automobile
- 1947-SERIES-40 STEP-COURTESY-LAMP Automobile
- 1947-SERIES-50 DOME-LAMP Automobile
- 1947-SERIES-50 STEP-COURTESY-LAMP Automobile
- 1947-SERIES-70 DOME-LAMP Automobile
- 1947-SERIES-70 STEP-COURTESY-LAMP Automobile
- 1948-SERIES-40 DOME-LAMP Automobile
- 1948-SERIES-40 STEP-COURTESY-LAMP Automobile
- 1948-SERIES-50 DOME-LAMP Automobile

filament
close-up view:



C = coiled

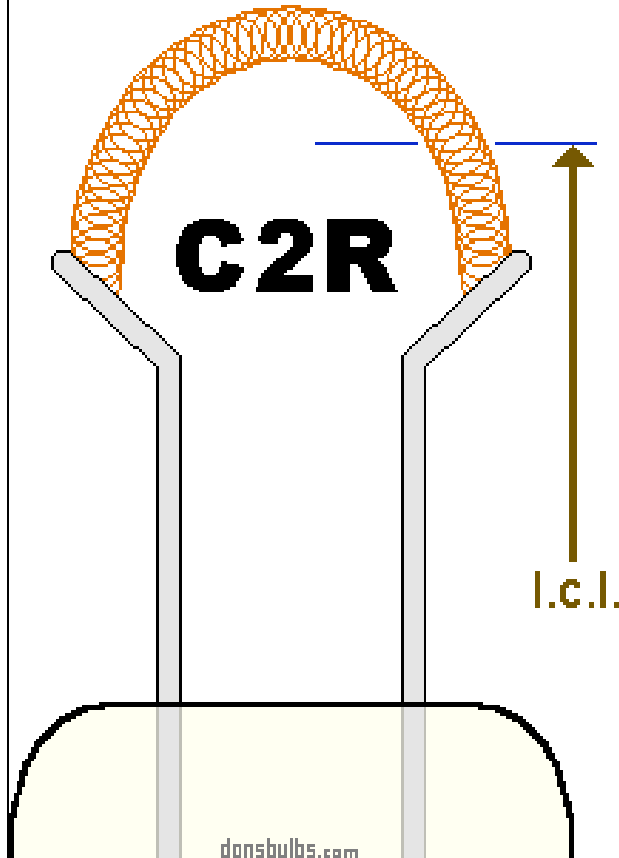

typical shape of C2R filament (not to scale)

- 1948-SERIES-50 STEP-COURTESY-LAMP Automobile
- 1948-SERIES-70 DOME-LAMP Automobile
- 1948-SERIES-70 STEP-COURTESY-LAMP Automobile
- 1949-SERIES-40 DOME-LAMP Automobile
- 1949-SERIES-40 STEP-COURTESY-LAMP Automobile
- 1952-SERIES-50 DOME-LAMP Automobile
- 1952-SERIES-70 DOME-LAMP Automobile

Cadillac

- 1946 DOME-LAMP Automobile
- 1946 STEP-COURTESY-LAMP Automobile
- 1947 DOME-LAMP Automobile
- 1947 STEP-COURTESY-LAMP Automobile
- 1948 DOME-LAMP Automobile
- 1948 STEP-COURTESY-LAMP Automobile
- 1949 DOME-LAMP Automobile
- 1949 STEP-COURTESY-LAMP Automobile
- 1950 DOME-LAMP Automobile
- 1950 STEP-COURTESY-LAMP Automobile
- 1951 DOME-LAMP Automobile
- 1951 STEP-COURTESY-LAMP Automobile
- 1952 DOME-LAMP Automobile

Chrysler

- 1953-C-56,58,66 BRAKE-SIGNAL-LAMP Automobile
- 1953-C56,58,66 BRAKE-SIGNAL-LAMP Automobile
- 1954-C-62,63,64 BRAKE-SIGNAL-LAMP Automobile
- 1954-C62,63,64 BRAKE-SIGNAL-LAMP Automobile
- 1955-6-VOLT-C-67,68,69 BRAKE-SIGNAL-LAMP Automobile
- 1955-6-VOLT-C67,68,69 BRAKE-SIGNAL-LAMP Automobile

Desoto

- 1953 BRAKE-SIGNAL-LAMP Automobile
- 1954 BRAKE-SIGNAL-LAMP Automobile
- 1955-6-VOLT BRAKE-SIGNAL-LAMP Automobile

Dodge

- 1953 BRAKE-SIGNAL-LAMP Automobile
- 1954 BRAKE-SIGNAL-LAMP Automobile
- 1955-6-VOLT BRAKE-SIGNAL-LAMP Automobile

BA15d

double contact bayonet

DC bayonet

double contact candelabra bayonet

SBC (British small bayonet cap)

IEC7004-11
DIN49721

IEC7005-13
DIN49642T6

A19A
A19B
A19C
A19D
B15d
SBC
DC
BD

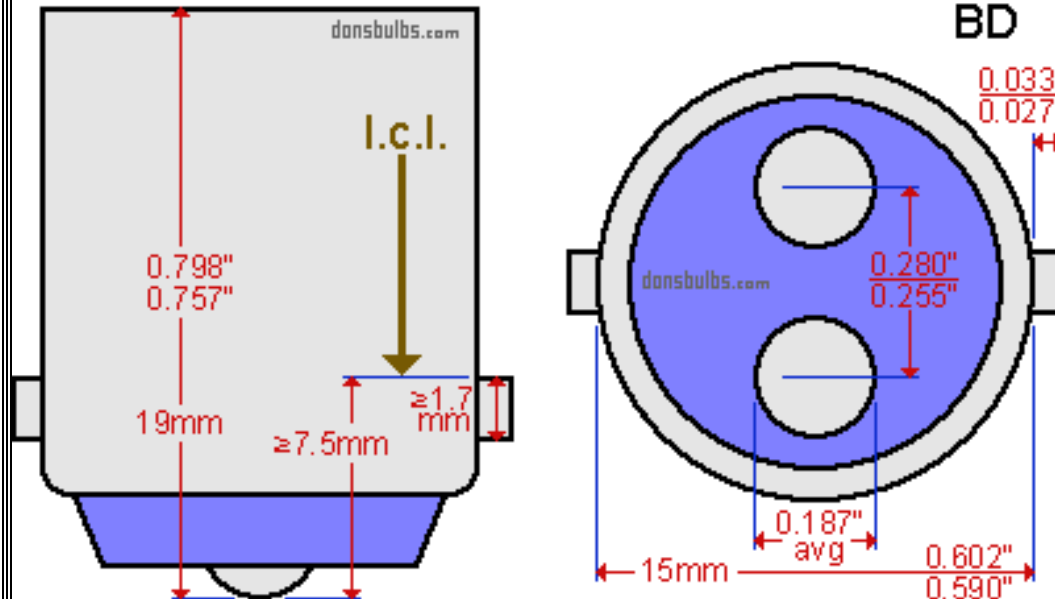

industry standards for base:

BA15d - Double Contact Candelabra Bayonet (or D.C.Bayonet) (not to scale)

Elmo

912 EDITOR Projector Slide / Filmstrip

Eumig USA Incorporated

V-7-A Viewer Film

V-7 Viewer Film

V-VII-A Viewer Film

V-VIIA Viewer Film

V-VII Viewer Film

V7-A Viewer Film

V7A Viewer Film

V7 Viewer Film

Ford

1951 DOME-LAMP Automobile

Frazer

1948 STEP-COURTESY-LAMP Automobile

Lincoln Zephyr

1949 DOME-LAMP Automobile

1949 STEP-COURTESY-LAMP Automobile

1950 DOME-LAMP Automobile

Marco

6V PRO. PERIM. RED CHART Medical

PRO.-PERIMETER-RED-CHART-6V Medical

Mercury

1949 DOME-LAMP Automobile

1950 STEP-COURTESY-LAMP Automobile

1951 STEP-COURTESY-LAMP Automobile

MH Marketing Hobby

V-7-A Microfilm

V-7A Microfilm

V-7 Microfilm

V-VII-A Microfilm

V-VIIA Microfilm

V-VII Microfilm

V7A Microfilm

V7 Microfilm

Oldsmobile

1941 DOME-LAMP Automobile

1942 DOME-LAMP Automobile
1943 DOME-LAMP Automobile
1944 DOME-LAMP Automobile
1945 DOME-LAMP Automobile
1946 DOME-LAMP Automobile
1951-SERIES-88 DOME-LAMP Automobile
1951-SERIES-98 DOME-LAMP Automobile
1952-SERIES-88 DOME-LAMP Automobile
1952-SERIES-98 DOME-LAMP Automobile

Packard

1948-DELUXE,SUPER,CUSTOM DOME-LAMP Automobile
1948-DELUXE,SUPER,CUSTOM STEP-COURTESY-LAMP Automobile
1948-STANDARD DOME-LAMP Automobile
1948-STANDARD STEP-COURTESY-LAMP Automobile
1949-DELUXE,SUPER,CUSTOM DOME-LAMP Automobile
1949-DELUXE,SUPER,CUSTOM STEP-COURTESY-LAMP Automobile
1949-STANDARD DOME-LAMP Automobile
1949-STANDARD STEP-COURTESY-LAMP Automobile
1950-STANDARD,DELUXE,SUPER,CUSTOM DOME-LAMP Automobile
1950-STANDARD,DELUXE,SUPER,CUSTOM STEP-COURTESY-LAMP Automobile
1950-TAXI DOME-LAMP Automobile
1950-TAXI STEP-COURTESY-LAMP Automobile
1951 DOME-LAMP Automobile
1951 STEP-COURTESY-LAMP Automobile
1952 STEP-COURTESY-LAMP Automobile
1953-2601,2611,2631 STEP-COURTESY-LAMP Automobile
1953-2602,2606,2626 STEP-COURTESY-LAMP Automobile
1953 MAP-LAMP Automobile
1954 MAP-LAMP Automobile
1954 STEP-COURTESY-LAMP Automobile

Plymouth

1953 BRAKE-SIGNAL-LAMP Automobile

1953 MAP-LAMP Automobile

1954 BRAKE-SIGNAL-LAMP Automobile

1954 MAP-LAMP Automobile

1955-6-VOLT BRAKE-SIGNAL-LAMP Automobile

Pontiac

1941 DOME-LAMP Automobile

1942 DOME-LAMP Automobile

1946 DOME-LAMP Automobile

1947 DOME-LAMP Automobile

1952 STEP-COURTESY-LAMP Automobile

1953-DELUXE DOME-LAMP Automobile

1954 DOME-LAMP Automobile