

87 is known as: 87-USA

87-USA bulb specifications:

category: **Miniature**
volt: **6.8**
amp: **1.91**
watt: **13**
base: **BA15s** - Single Contact Candelabra Bayonet (or S.C.Bayonet)
glass: **S8**
filament: **C2R**
fil.res.: **3.56** ohm
m.o.l.: **2** inches
l.c.l.: **1.13** inches
burn pos: burn lamp in **ANY** position
i.lumens: **189**
cp: **15**
d.hours: **300**
notes:
Indicator Lamp
uses socket: [DB-BA15S1](#)

87-USA also known as

Cross-Reference:

87-USA
031293409867
031293409867-EIKO
4511-STANLEY
606500U-MICROLAMP
87
87-EIKO
87-GE
87-TUNG-SOL
87-TUNGSOL
A4511
AB2902
AGI-3411
AGI-AS810
AS-3611
AS-3611-AIDLITE
AS3611
AS4601
AT4401
CM87
CM87-AIDLITE
MB-00870
MB00870
STANLEY-4511
TS-87
TS-87-CHICAGO-MINIATURE
TS-87-CM
TS87
TS87-CHICAGO-MINIATURE
TS87-CM

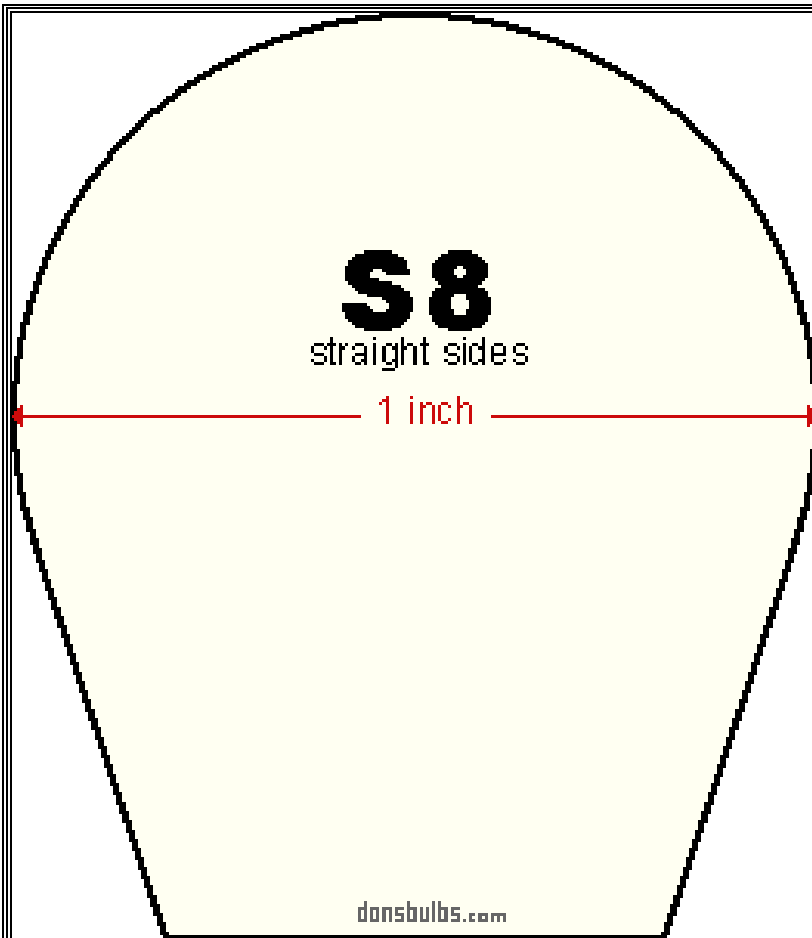

usual shape of S8 glass envelopes (not to scale)

87-USA have been found in equipment:

Ahrens Fox

1953-COMMERCIAL-6-VOLT STOP-LAMP Automobile / Truck

1954-COMMERCIAL-6-VOLT STOP-LAMP Automobile / Truck

1955-COMMERCIAL-6-VOLT STOP-LAMP Automobile / Truck

Autocar

1942-6-VOLT-CABOVER-ENGINE DOME-LAMP Automobile / Truck

1942-6-VOLT-CONVENTIONAL STOP-LAMP Automobile / Truck

1952-DIESEL-6-VOLT DOME-LAMP Automobile / Truck

1952-GAS-6-VOLT DOME-LAMP Automobile / Truck

Available

1942 DOME-LAMP Automobile / Truck

Brockway

1947-6-VOLT STOP-LAMP Automobile / Truck

1948-6-VOLT STOP-LAMP Automobile / Truck

1949-6-VOLT STOP-LAMP Automobile / Truck

1950-6-VOLT STOP-LAMP Automobile / Truck

1951-6-VOLT DOME-LAMP Automobile / Truck

1952-6-VOLT DOME-LAMP Automobile / Truck

1953-6-VOLT DOME-LAMP Automobile / Truck

1954-6-VOLT DOME-LAMP Automobile / Truck

1955-6-VOLT DOME-LAMP Automobile / Truck

Cadillac

1937 DOME-LAMP Automobile

1938 DOME-LAMP Automobile

1940 DOME-LAMP Automobile

Chevrolet

1941 DOME-LAMP Automobile / Truck

1941 STOP-LAMP Automobile / Truck

1942 DOME-LAMP Automobile / Truck

1946 DOME-LAMP Automobile / Truck

1947-1-TON DOME-LAMP Automobile / Truck

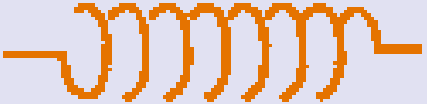
filament
close-up view:

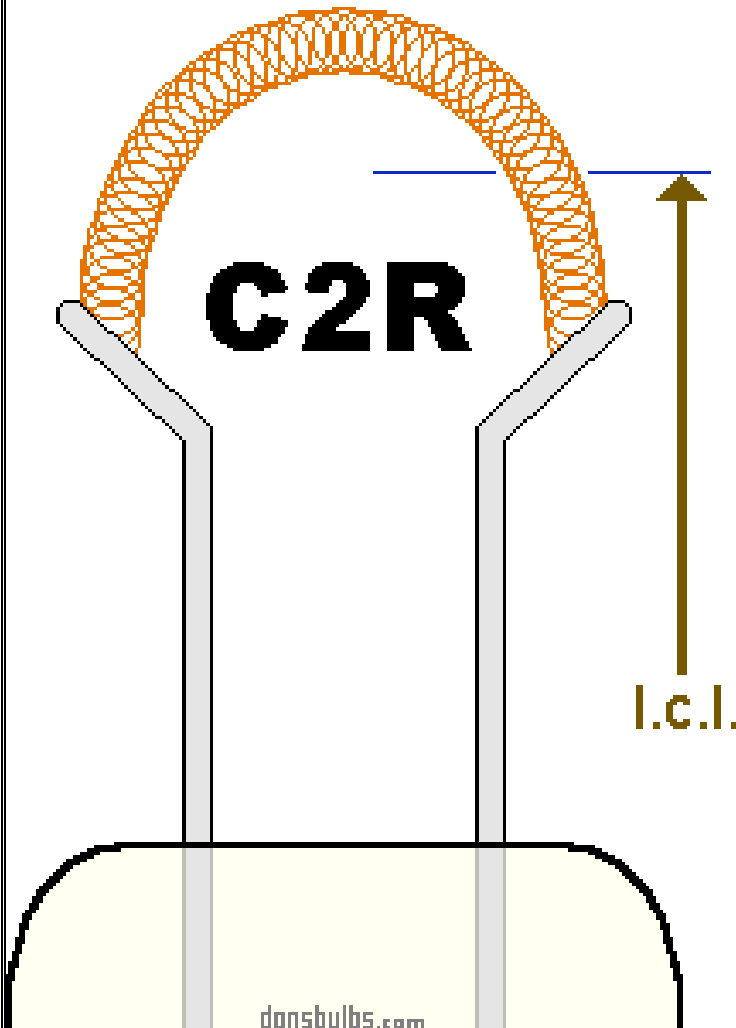
C = coiled



typical shape of **C2R** filament (not to scale)

- 1947-1/2-TON DOME-LAMP Automobile / Truck
- 1947-1/2TON DOME-LAMP Automobile / Truck
- 1947-1TON DOME-LAMP Automobile / Truck
- 1947 DOME-LAMP Automobile / Truck
- 1948-1-TON DOME-LAMP Automobile / Truck
- 1948-1/2-TON DOME-LAMP Automobile / Truck
- 1948-1/2TON DOME-LAMP Automobile / Truck
- 1948-1TON DOME-LAMP Automobile / Truck
- 1948 DOME-LAMP Automobile / Truck
- 1949-1-TON DOME-LAMP Automobile / Truck
- 1949-1/2-TON DOME-LAMP Automobile / Truck
- 1949-1/2TON DOME-LAMP Automobile / Truck
- 1949-1TON DOME-LAMP Automobile / Truck
- 1949 DOME-LAMP Automobile / Truck
- 1950-1-TON DOME-LAMP Automobile / Truck
- 1950-1/2-TON DOME-LAMP Automobile / Truck
- 1950-1/2TON DOME-LAMP Automobile / Truck
- 1950-1TON DOME-LAMP Automobile / Truck
- 1950 DOME-LAMP Automobile / Truck
- 1951-1-TON DOME-LAMP Automobile / Truck
- 1951-1/2-TON DOME-LAMP Automobile / Truck
- 1951-1/2TON DOME-LAMP Automobile / Truck
- 1951-1TON DOME-LAMP Automobile / Truck
- 1951 DOME-LAMP Automobile / Truck
- 1952-1-TON DOME-LAMP Automobile / Truck
- 1952-1/2-TON DOME-LAMP Automobile / Truck
- 1952-1/2TON DOME-LAMP Automobile / Truck
- 1952-1TON DOME-LAMP Automobile / Truck
- 1952 DOME-LAMP Automobile / Truck
- 1953-1-1/2-TON DOME-LAMP Automobile / Truck
- 1953-1-1/2TON DOME-LAMP Automobile / Truck
- 1953-1-TON DOME-LAMP Automobile / Truck
- 1953-1/2-TON DOME-LAMP Automobile / Truck
- 1953-1/2TON DOME-LAMP Automobile / Truck
- 1953-1TON DOME-LAMP Automobile / Truck
- 1953-2-TON DOME-LAMP Automobile / Truck
- 1953-2TON DOME-LAMP Automobile / Truck
- 1953-3/4-TON DOME-LAMP Automobile / Truck

BA15s B15s

single contact bayonet

SC bayonet

single contact candelabra bayonet

SCC (British single centre contact)

IEC7004-11A9
DIN49720

IEC7005-13
DIN49642T6

E
E25W
F
F15W
G
P
P21W
R
R5W
R10W
R18W
R21W
U
U45W

A18B
A18C
A18F
A18G
SCC
SC

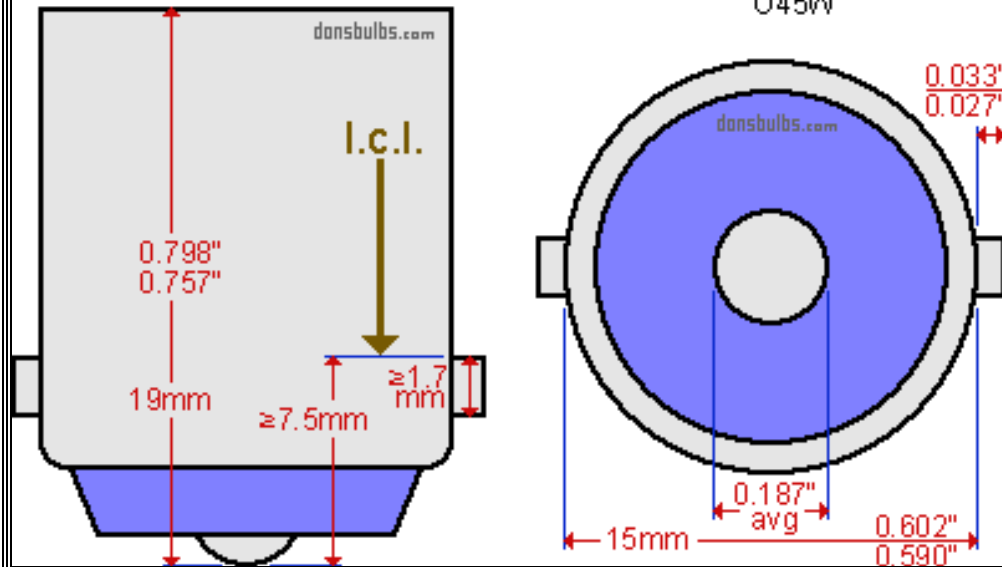

industry standards for base:

BA15s - Single Contact Candelabra Bayonet (or S.C.Bayonet) (not to scale)

- 1953-3/4TON DOME-LAMP Automobile / Truck
- 1953 TRUNK-COMPARTMENT-LAMP Automobile
- 1953 UNDER-HOOD-LAMP Automobile
- 1954-1-TON DOME-LAMP Automobile / Truck
- 1954-1/2-TON DOME-LAMP Automobile / Truck
- 1954-1/2TON DOME-LAMP Automobile / Truck
- 1954-1TON DOME-LAMP Automobile / Truck
- 1954 DOME-LAMP Automobile / Truck
- 1954 STEP-COURTESY-LAMP Automobile
- 1954 TRUNK-COMPARTMENT-LAMP Automobile
- 1954 UNDER-HOOD-LAMP Automobile
- 1955-1-TON DOME-LAMP Automobile / Truck
- 1955-1/2-TON DOME-LAMP Automobile / Truck
- 1955-1/2TON DOME-LAMP Automobile / Truck
- 1955-1TON DOME-LAMP Automobile / Truck
- 1955 DOME-LAMP Automobile / Truck

Chrysler

- 1937-C-17 DOME-LAMP Automobile
- 1937-C-17 STOP-LAMP Automobile
- 1937-C17 DOME-LAMP Automobile
- 1937-C17 STOP-LAMP Automobile
- 1937 DOME-LAMP Automobile
- 1938 DOME-LAMP Automobile
- 1939 DOME-LAMP Automobile
- 1940 DOME-LAMP Automobile
- 1941 DOME-LAMP Automobile
- 1942 DOME-LAMP Automobile
- 1946 DOME-LAMP Automobile
- 1947 DOME-LAMP Automobile
- 1948 DOME-LAMP Automobile
- 1950 STEP-COURTESY-LAMP Automobile
- 1953-C-56,58,66 TRUNK-COMPARTMENT-LAMP Automobile
- 1953-C-56,58,66 UNDER-HOOD-LAMP Automobile
- 1953-C56,58,66 TRUNK-COMPARTMENT-LAMP Automobile
- 1953-C56,58,66 UNDER-HOOD-LAMP Automobile
- 1954-C-62,63,64 TRUNK-COMPARTMENT-LAMP Automobile

1954-C-62,63,64 UNDER-HOOD-LAMP Automobile
1954-C62,63,64 TRUNK-COMPARTMENT-LAMP Automobile
1954-C62,63,64 UNDER-HOOD-LAMP Automobile
1955-6-VOLT-C-67,68,69 TRUNK-COMPARTMENT-
LAMP Automobile
1955-6-VOLT-C-67,68,69 UNDER-HOOD-LAMP Automobile
1955-6-VOLT-C67,68,69 TRUNK-COMPARTMENT-
LAMP Automobile
1955-6-VOLT-C67,68,69 UNDER-HOOD-LAMP Automobile

Corbitt

1946-6-VOLT STOP-LAMP Automobile / Truck
1947-6-VOLT STOP-LAMP Automobile / Truck
1948-6-VOLT STOP-LAMP Automobile / Truck
1949-6-VOLT STOP-LAMP Automobile / Truck
1950-6-VOLT STOP-LAMP Automobile / Truck
1951-6-VOLT STOP-LAMP Automobile / Truck
1952-6-VOLT STOP-LAMP Automobile / Truck

Desoto

1937 DOME-LAMP Automobile
1938 DOME-LAMP Automobile
1940 DOME-LAMP Automobile
1941 DOME-LAMP Automobile
1942 DOME-LAMP Automobile
1946 DOME-LAMP Automobile
1947 DOME-LAMP Automobile
1948 DOME-LAMP Automobile
1953 TRUNK-COMPARTMENT-LAMP Automobile
1953 UNDER-HOOD-LAMP Automobile
1954 TRUNK-COMPARTMENT-LAMP Automobile
1954 UNDER-HOOD-LAMP Automobile
1955-6-VOLT TRUNK-COMPARTMENT-LAMP Automobile
1955-6-VOLT UNDER-HOOD-LAMP Automobile

Diamond T

1947-6-VOLT DOME-LAMP Automobile / Truck
1948-6-VOLT DOME-LAMP Automobile / Truck
1949-6-VOLT DOME-LAMP Automobile / Truck
1950-6-VOLT DOME-LAMP Automobile / Truck
1951-6-VOLT DOME-LAMP Automobile / Truck

1952-6-VOLT DOME-LAMP Automobile / Truck
1953-6-VOLT DOME-LAMP Automobile / Truck
1954-6-VOLT DOME-LAMP Automobile / Truck
1955-6-VOLT DOME-LAMP Automobile / Truck
1956-6-VOLT DOME-LAMP Automobile / Truck
1957-6-VOLT DOME-LAMP Automobile / Truck

Divco

1954 DOME-LAMP Automobile / Truck
1955 DOME-LAMP Automobile / Truck
1956 DOME-LAMP Automobile / Truck
1957 DOME-LAMP Automobile / Truck

Dodge

1936 DOME-LAMP Automobile
1938 DOME-LAMP Automobile
1939 DOME-LAMP Automobile
1940 DOME-LAMP Automobile
1941 DOME-LAMP Automobile / Truck
1942 DOME-LAMP Automobile / Truck
1946 DOME-LAMP Automobile / Truck
1947 DOME-LAMP Automobile / Truck
1948 DOME-LAMP Automobile / Truck
1949 DOME-LAMP Automobile / Truck
1950 DOME-LAMP Automobile / Truck
1951 DOME-LAMP Automobile / Truck
1952 DOME-LAMP Automobile / Truck
1953 TRUNK-COMPARTMENT-LAMP Automobile
1953 UNDER-HOOD-LAMP Automobile
1954 TRUNK-COMPARTMENT-LAMP Automobile
1954 UNDER-HOOD-LAMP Automobile
1955-6-VOLT TRUNK-COMPARTMENT-LAMP Automobile
1955-6-VOLT UNDER-HOOD-LAMP Automobile

Duplex

1950-6-VOLT DOME-LAMP Automobile / Truck
1951-6-VOLT DOME-LAMP Automobile / Truck
1952-6-VOLT DOME-LAMP Automobile / Truck
1953-6-VOLT DOME-LAMP Automobile / Truck
1954-6-VOLT DOME-LAMP Automobile / Truck
1955-6-VOLT DOME-LAMP Automobile / Truck

Federal Manufacturing Engineering Corporation

1942-6-VOLT DOME-LAMP Automobile / Truck

Ford

1940 DOME-LAMP Automobile / Truck

1941 DOME-LAMP Automobile / Truck

1942 DOME-LAMP Automobile / Truck

1946 DOME-LAMP Automobile / Truck

1947 DOME-LAMP Automobile / Truck

1948-6-VOLT DOME-LAMP Automobile / Truck

1949-6-VOLT DOME-LAMP Automobile / Truck

1950-6-VOLT DOME-LAMP Automobile / Truck

1951-6-VOLT DOME-LAMP Automobile / Truck

1952-6-VOLT DOME-LAMP Automobile / Truck

1953 UNDER-HOOD-LAMP Automobile

1954 DOME-LAMP Automobile / Truck

1954 UNDER-HOOD-LAMP Automobile

1955-6-VOLT UNDER-HOOD-LAMP Automobile

1955 DOME-LAMP Automobile / Truck

FWD

1953-6-VOLT DOME-LAMP Automobile / Truck

1954-6-VOLT DOME-LAMP Automobile / Truck

GMC

1940 STOP-LAMP Automobile / Truck

1941 STOP-LAMP Automobile / Truck

1942-500,890;EFP-240 DIRECTION-LAMP Automobile / Truck

1942-500,890;EFP-240 STOP-LAMP Automobile / Truck

1942-500,890;EFP240 DIRECTION-LAMP Automobile / Truck

1942-500,890;EFP240 STOP-LAMP Automobile / Truck

1946-500,890;EFP-240 DIRECTION-LAMP Automobile / Truck

1946-500,890;EFP-240 STOP-LAMP Automobile / Truck

1946-500,890;EFP240 DIRECTION-LAMP Automobile / Truck

1946-500,890;EFP240 STOP-LAMP Automobile / Truck

1947-500,890;EFP-240 DIRECTION-LAMP Automobile / Truck

1947-500,890;EFP-240 STOP-LAMP Automobile / Truck

1947-500,890;EFP240 DIRECTION-LAMP Automobile / Truck

1947-500,890;EFP240 STOP-LAMP Automobile / Truck

1948-500,890;EFP-240 DIRECTION-LAMP Automobile / Truck

1948-500,890;EFP-240 STOP-LAMP Automobile / Truck

1948-500,890;EFP240 DIRECTION-LAMP Automobile / Truck
1948-500,890;EFP240 STOP-LAMP Automobile / Truck
1949-FC,FF DOME-LAMP Automobile / Truck
1949-SOME-HC,ALL-HF DOME-LAMP Automobile / Truck
1949-SOME-HC,ALL-HF STOP-LAMP Automobile / Truck
1950-FC,FCS,FP,HCS-400,HCW-400 DOME-
LAMP Automobile / Truck
1950-FC,FCS,FP,HCS400,HCW400 DOME-LAMP Automobile
/ Truck
1950-HC-450,470,HCS-450,HF-450,470,FF DOME-
LAMP Automobile / Truck
1950-HC-450,470,HCS-450,HF-450,470,FF STOP-
LAMP Automobile / Truck
1950-HC450,470,HCS450,HF450,470,FF DOME-
LAMP Automobile / Truck
1950-HC450,470,HCS450,HF450,470,FF STOP-
LAMP Automobile / Truck
1950-SOME-HC,HCW,HF DOME-LAMP Automobile / Truck
1950-SOME-HC,HCW,HF STOP-LAMP Automobile / Truck
1951-FC,FCS,FP,HCS-400,HCW-400 DOME-
LAMP Automobile / Truck
1951-FC,FCS,FP,HCS400,HCW400 DOME-LAMP Automobile
/ Truck
1951-HC-450,470,HCS-450,HF-450,470,FF DOME-
LAMP Automobile / Truck
1951-HC-450,470,HCS-450,HF-450,470,FF STOP-
LAMP Automobile / Truck
1951-HC450,470,HCS450,HF450,470,FF DOME-
LAMP Automobile / Truck
1951-HC450,470,HCS450,HF450,470,FF STOP-
LAMP Automobile / Truck
1951-SOME-HC,HCW,HF DOME-LAMP Automobile / Truck
1951-SOME-HC,HCW,HF STOP-LAMP Automobile / Truck
1952-FC,FCS,FP,HCS-400,HCW-400 DOME-
LAMP Automobile / Truck
1952-FC,FCS,FP,HCS400,HCW400 DOME-LAMP Automobile
/ Truck
1952-HC-450,470,HCS-450,HF-450,470,FF DOME-

LAMP Automobile / Truck
1952-HC-450,470,HCS-450,HF-450,470,FF STOP-
LAMP Automobile / Truck
1952-HC450,470,HCS450,HF450,470,FF DOME-
LAMP Automobile / Truck
1952-HC450,470,HCS450,HF450,470,FF STOP-
LAMP Automobile / Truck
1952-SOME-HC,HCW,HF DOME-LAMP Automobile / Truck
1952-SOME-HC,HCW,HF STOP-LAMP Automobile / Truck
1953-FC,FCS,FP,HCS-400,HCW-400 DOME-
LAMP Automobile / Truck
1953-FC,FCS,FP,HCS400,HCW400 DOME-LAMP Automobile
/ Truck
1953-HC-450,470,HCS-450,HF-450,470,FF DOME-
LAMP Automobile / Truck
1953-HC-450,470,HCS-450,HF-450,470,FF STOP-
LAMP Automobile / Truck
1953-HC450,470,HCS450,HF450,470,FF DOME-
LAMP Automobile / Truck
1953-HC450,470,HCS450,HF450,470,FF STOP-
LAMP Automobile / Truck
1953-SOME-HC,HCW,HF DOME-LAMP Automobile / Truck
1953-SOME-HC,HCW,HF STOP-LAMP Automobile / Truck
1954-6-VOLT DOME-LAMP Automobile / Truck
1955-6-VOLT STOP-LAMP Automobile / Truck

Hahn

1942-6-VOLT STOP-LAMP Automobile / Truck
1946-6-VOLT STOP-LAMP Automobile / Truck
1947-6-VOLT STOP-LAMP Automobile / Truck
1948-6-VOLT STOP-LAMP Automobile / Truck
1949-6-VOLT STOP-LAMP Automobile / Truck
1950-6-VOLT STOP-LAMP Automobile / Truck

Hudson

1937 DOME-LAMP Automobile
1938 DOME-LAMP Automobile
1939 DOME-LAMP Automobile
1940 DOME-LAMP Automobile
1941 DOME-LAMP Automobile

1946 DOME-LAMP Automobile
1947 DOME-LAMP Automobile
1948-COMMODORE STEP-COURTESY-LAMP Automobile
1948-SUPER DOME-LAMP Automobile
1949-COMMODORE STEP-COURTESY-LAMP Automobile
1949-SUPER DOME-LAMP Automobile
1950-COMMODORE DOME-LAMP Automobile
1950-COMMODORE STEP-COURTESY-LAMP Automobile
1950-SUPER DOME-LAMP Automobile
1951-COMMODORE DOME-LAMP Automobile
1951-COMMODORE STEP-COURTESY-LAMP Automobile
1951-SUPER DOME-LAMP Automobile
1952 DOME-LAMP Automobile
1952 STEP-COURTESY-LAMP Automobile
1953 DOME-LAMP Automobile
1953 STEP-COURTESY-LAMP Automobile
1953 TRUNK-COMPARTMENT-LAMP Automobile
1953 UNDER-HOOD-LAMP Automobile
1954 DOME-LAMP Automobile
1954 STEP-COURTESY-LAMP Automobile
1954 TRUNK-COMPARTMENT-LAMP Automobile
1954 UNDER-HOOD-LAMP Automobile

International

1942-6-VOLT DIRECTION-LAMP Automobile / Truck
1942-6-VOLT DOME-LAMP Automobile / Truck
1946-6-VOLT DIRECTION-LAMP Automobile / Truck
1946-6-VOLT DOME-LAMP Automobile / Truck
1947-6-VOLT DIRECTION-LAMP Automobile / Truck
1947-6-VOLT DOME-LAMP Automobile / Truck
1948-6-VOLT DIRECTION-LAMP Automobile / Truck
1948-6-VOLT DOME-LAMP Automobile / Truck
1949-6-VOLT DOME-LAMP Automobile / Truck
1950-6-VOLT DOME-LAMP Automobile / Truck
1951-6-VOLT DOME-LAMP Automobile / Truck
1952-6-VOLT DOME-LAMP Automobile / Truck
1953-6-VOLT DOME-LAMP Automobile / Truck
1953-RM-120,150,RB-140 DOME-LAMP Automobile / Truck
1953-RM120,150,RB140 DOME-LAMP Automobile / Truck

1954-6-VOLT DOME-LAMP Automobile / Truck
1955-6-VOLT DOME-LAMP Automobile / Truck

Kaiser

1955 REAR-LAMP Automobile

Kenworth

1942-6-VOLT STOP-LAMP Automobile / Truck

La Salle

1939 DOME-LAMP Automobile

1940 DOME-LAMP Automobile

Lincoln Zephyr

1954 UNDER-HOOD-LAMP Automobile

1955-6-VOLT UNDER-HOOD-LAMP Automobile

Mack

1942-6-VOLT DOME-LAMP Automobile / Truck

1946-6-VOLT DOME-LAMP Automobile / Truck

1947-6-VOLT DOME-LAMP Automobile / Truck

Mercury

1939 INDICATOR-LAMP Automobile

1953 UNDER-HOOD-LAMP Automobile

1954 UNDER-HOOD-LAMP Automobile

1955-6-VOLT UNDER-HOOD-LAMP Automobile

Oshkosh

1941-6-VOLT DIRECTION-LAMP Automobile / Truck

1941-6-VOLT STOP-LAMP Automobile / Truck

1942-6-VOLT DIRECTION-LAMP Automobile / Truck

1942-6-VOLT STOP-LAMP Automobile / Truck

1944-6-VOLT DIRECTION-LAMP Automobile / Truck

1944-6-VOLT DOME-LAMP Automobile / Truck

1944-6-VOLT STOP-LAMP Automobile / Truck

1945-6-VOLT DIRECTION-LAMP Automobile / Truck

1945-6-VOLT DOME-LAMP Automobile / Truck

1945-6-VOLT STOP-LAMP Automobile / Truck

1946-6-VOLT DIRECTION-LAMP Automobile / Truck

1946-6-VOLT DOME-LAMP Automobile / Truck

1946-6-VOLT STOP-LAMP Automobile / Truck

1947-6-VOLT DIRECTION-LAMP Automobile / Truck

1947-6-VOLT DOME-LAMP Automobile / Truck

1947-6-VOLT STOP-LAMP Automobile / Truck

Packard

1937 STOP-LAMP Automobile

1938-6,120 STOP-LAMP Automobile

1938-SUPER-8,12 STOP-LAMP Automobile

1938-SUPER8,12 STOP-LAMP Automobile

1939-12 STOP-LAMP Automobile

Plymouth

1936 DOME-LAMP Automobile

1937 DOME-LAMP Automobile

1938 DOME-LAMP Automobile

1939 DOME-LAMP Automobile

1940 DOME-LAMP Automobile

1941 DOME-LAMP Automobile

1942 DOME-LAMP Automobile

1946 DOME-LAMP Automobile

1947 DOME-LAMP Automobile

1948 DOME-LAMP Automobile

1953 TRUNK-COMPARTMENT-LAMP Automobile

1953 UNDER-HOOD-LAMP Automobile

1954 TRUNK-COMPARTMENT-LAMP Automobile

1954 UNDER-HOOD-LAMP Automobile

1955-6-VOLT TRUNK-COMPARTMENT-LAMP Automobile

1955-6-VOLT UNDER-HOOD-LAMP Automobile

Pontiac

1937 STOP-LAMP Automobile

1938 STOP-LAMP Automobile

1953 TRUNK-COMPARTMENT-LAMP Automobile

1953 UNDER-HOOD-LAMP Automobile

1954 TRUNK-COMPARTMENT-LAMP Automobile

1954 UNDER-HOOD-LAMP Automobile

Renault

PRE-1958 LICENSE-PLATE-LAMP Automobile

REO

1941 DOME-LAMP Automobile / Truck

1942 DOME-LAMP Automobile / Truck

1946-6-VOLT DOME-LAMP Automobile / Truck

1947-6-VOLT DOME-LAMP Automobile / Truck

1948-6-VOLT DOME-LAMP Automobile / Truck
1949-6-VOLT DOME-LAMP Automobile / Truck
1950-6-VOLT DOME-LAMP Automobile / Truck
1951-6-VOLT DIRECTION-LAMP Automobile / Truck
1951-6-VOLT DOME-LAMP Automobile / Truck
1953-6-VOLT DOME-LAMP Automobile / Truck
1954-6-VOLT DOME-LAMP Automobile / Truck
1955-6-VOLT DOME-LAMP Automobile / Truck
1956-6-VOLT DOME-LAMP Automobile / Truck

Seagrave

1942-6-VOLT STOP-LAMP Automobile / Truck
1946-6-VOLT DOME-LAMP Automobile / Truck
1946-6-VOLT STOP-LAMP Automobile / Truck
1947-6-VOLT DOME-LAMP Automobile / Truck
1947-6-VOLT STOP-LAMP Automobile / Truck
1948-6-VOLT DOME-LAMP Automobile / Truck
1948-6-VOLT STOP-LAMP Automobile / Truck
1949-6-VOLT DOME-LAMP Automobile / Truck
1949-6-VOLT STOP-LAMP Automobile / Truck
1950-6-VOLT DOME-LAMP Automobile / Truck
1950-6-VOLT STOP-LAMP Automobile / Truck
1951-6-VOLT DOME-LAMP Automobile / Truck
1951-6-VOLT STOP-LAMP Automobile / Truck

Stewart

1942-6-VOLT DOME-LAMP Automobile / Truck
1942-6-VOLT STOP-LAMP Automobile / Truck

Studebaker

1938 DOME-LAMP Automobile
1939 DOME-LAMP Automobile
1940 DOME-LAMP Automobile
1941 DOME-LAMP Automobile / Truck
1950 DOME-LAMP Automobile
1953 UNDER-HOOD-LAMP Automobile
1955-6-VOLT UNDER-HOOD-LAMP Automobile

Walter Voss Incorporated

1947-6-VOLT DIRECTION-LAMP Automobile / Truck
1947-6-VOLT DOME-LAMP Automobile / Truck
1947-6-VOLT STOP-LAMP Automobile / Truck

1948-6-VOLT DIRECTION-LAMP Automobile / Truck
1948-6-VOLT DOME-LAMP Automobile / Truck
1948-6-VOLT STOP-LAMP Automobile / Truck
1949-6-VOLT DIRECTION-LAMP Automobile / Truck
1949-6-VOLT DOME-LAMP Automobile / Truck
1949-6-VOLT STOP-LAMP Automobile / Truck
1950-6-VOLT DIRECTION-LAMP Automobile / Truck
1950-6-VOLT DOME-LAMP Automobile / Truck
1950-6-VOLT STOP-LAMP Automobile / Truck
1951-6-VOLT DIRECTION-LAMP Automobile / Truck
1951-6-VOLT DOME-LAMP Automobile / Truck
1951-6-VOLT STOP-LAMP Automobile / Truck
1952-6-VOLT DIRECTION-LAMP Automobile / Truck
1952-6-VOLT DOME-LAMP Automobile / Truck
1952-6-VOLT STOP-LAMP Automobile / Truck
1953-6-VOLT DIRECTION-LAMP Automobile / Truck
1953-6-VOLT DOME-LAMP Automobile / Truck
1953-6-VOLT STOP-LAMP Automobile / Truck

White

1951-6-VOLT-3014,3016 DOME-LAMP Automobile / Truck
1951-6-VOLT-WC-14,WC-26 DOME-LAMP Automobile /
Truck
1951-6-VOLT-WC-14,WC26 DOME-LAMP Automobile /
Truck
1951-6-VOLT-WC14,WC26 DOME-LAMP Automobile / Truck
1952-6-VOLT-3014,3016 DOME-LAMP Automobile / Truck
1952-6-VOLT-WC-14,WC-26 DOME-LAMP Automobile /
Truck
1952-6-VOLT-WC-14,WC26 DOME-LAMP Automobile /
Truck
1952-6-VOLT-WC14,WC26 DOME-LAMP Automobile / Truck
1953-6-VOLT-3014,3016 DOME-LAMP Automobile / Truck
1953-6-VOLT-WC-14,WC-26 DOME-LAMP Automobile /
Truck
1953-6-VOLT-WC-14,WC26 DOME-LAMP Automobile /
Truck
1953-6-VOLT-WC14,WC26 DOME-LAMP Automobile / Truck
1954-6-VOLT-3014,3016 DOME-LAMP Automobile / Truck

1954-6-VOLT-WC-14,WC-26 DOME-LAMP Automobile /
Truck

1954-6-VOLT-WC-14,WC26 DOME-LAMP Automobile /
Truck

1954-6-VOLT-WC14,WC26 DOME-LAMP Automobile / Truck

1955-6-VOLT-3014,3016 DOME-LAMP Automobile / Truck

1955-6-VOLT-WC-14,WC-26 DOME-LAMP Automobile /
Truck

1955-6-VOLT-WC-14,WC26 DOME-LAMP Automobile /
Truck

1955-6-VOLT-WC14,WC26 DOME-LAMP Automobile / Truck

1956-6-VOLT-3014,3016 DOME-LAMP Automobile / Truck

1956-6-VOLT-WC-14,WC-26 DOME-LAMP Automobile /
Truck

1956-6-VOLT-WC-14,WC26 DOME-LAMP Automobile /
Truck

1956-6-VOLT-WC14,WC26 DOME-LAMP Automobile / Truck

1957-6-VOLT-3014,3016 DOME-LAMP Automobile / Truck

1957-6-VOLT-WC-14,WC-26 DOME-LAMP Automobile /
Truck

1957-6-VOLT-WC-14,WC26 DOME-LAMP Automobile /
Truck

1957-6-VOLT-WC14,WC26 DOME-LAMP Automobile / Truck

Willys

1947-4-T,2-T DOME-LAMP Automobile / Truck

1947-4T,2T DOME-LAMP Automobile / Truck

1947-STATION-WAGON DOME-LAMP Automobile

1948-STATION-WAGON DOME-LAMP Automobile

1949-4-T,2-T DOME-LAMP Automobile / Truck

1949-4T,2T DOME-LAMP Automobile / Truck

1949-STATION-WAGON,JEOPSTER DOME-
LAMP Automobile

1950 DOME-LAMP Automobile / Truck

1951 DOME-LAMP Automobile / Truck

1952 DOME-LAMP Automobile / Truck

1952 STEP-COURTESY-LAMP Automobile

1953-STATION-WAGON DOME-LAMP Automobile

1954-STATION-WAGON-4,6 DOME-LAMP Automobile

	<p>1954-STATION-WAGON4,6 DOME-LAMP Automobile 1954 DOME-LAMP Automobile / Truck 1955-PASS-CAR DOME-LAMP Automobile 1955-STATION-WAGON DOME-LAMP Automobile 1955 DOME-LAMP Automobile / Truck 1956 DOME-LAMP Automobile / Truck 1957 DOME-LAMP Automobile / Truck</p>
--	--