

# 94 is known as: 94-USA

## 94-USA bulb specifications:

category: **Miniature**  
volt: **12.8**  
amp: **1.04**  
watt: **13.3**  
base: **BA15d** - Double Contact Candelabra Bayonet (or D.C.Bayonet)  
glass: **S8**  
filament: **C2R**  
fil.res.: **12.3** ohm  
m.o.l.: **2** inches  
l.c.l.: **1.13** inches  
burn pos: burn lamp in **ANY** position  
i.lumens: **189**  
cp: **15**  
d.hours: **500**  
notes:  
**Aircraft Lamp**  
**Automotive Lamp**  
**Indicator Lamp**  
interior  
Marine  
stop lamp  
uses socket: [DB-BA15D1](#)

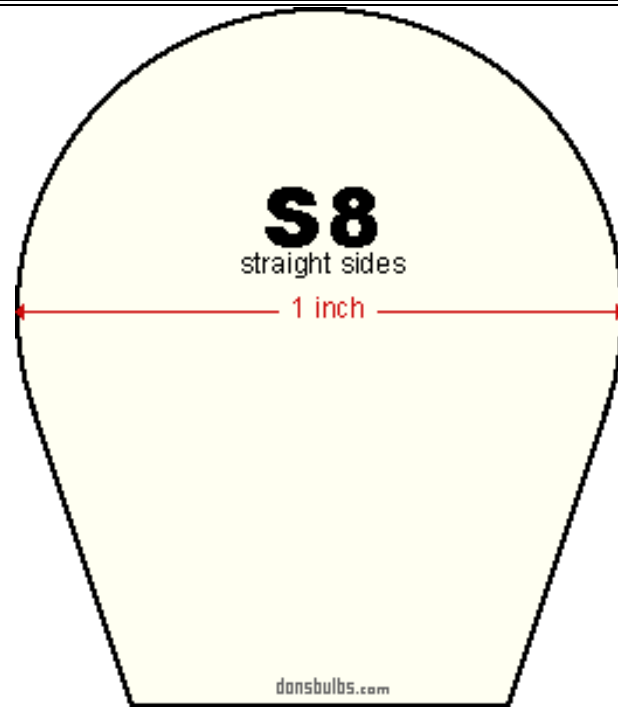

usual shape of **S8** glass envelopes (not to scale)

## 94-USA

also known as  
**Cross-Reference:**

94-USA  
031293410375  
031293410375-EIKO  
031293410382  
031293410382-EIKO  
15584-2  
20394-3  
2558

## 94-USA

have been found in equipment:

### Brockway

1950-12-VOLT DOME-LAMP Automobile / Truck  
1951-12-VOLT DOME-LAMP Automobile / Truck  
1952-12-VOLT DOME-LAMP Automobile / Truck  
1953-12-VOLT DOME-LAMP Automobile / Truck  
1954-12-VOLT DOME-LAMP Automobile / Truck  
1955-12-VOLT DOME-LAMP Automobile / Truck  
1956-12-VOLT DOME-LAMP Automobile / Truck  
1957-12-VOLT DOME-LAMP Automobile / Truck

2558-FOCUS  
25829  
25831  
34337  
361-TRIFA  
4522-STANLEY  
6240-00-014-2455  
7430  
7430-O  
7430-OS  
7430-OSRAM  
94  
94-BMC  
94-BP  
94-BP-EIKO  
94-EIKO  
94-GE  
94-LECTRA  
94-LUGON  
94-MAZDA  
94-N  
94-NORMAN  
94-WESTINGHOUSE  
94N  
AB3004  
AGI-3426  
AGI-AS857  
AS-3619  
AS-3619-AIDLITE  
AS3619  
AS3619-AIDLITE  
AS4609  
CM94  
FOCUS-2558  
MB-00940  
MB00940  
O-7430  
OS-7430

### **Cessna Aircraft**

150K-M Aircraft

A188B Aircraft

### **Chevrolet**

1956 DOME-LAMP Automobile / Truck

1957 DOME-LAMP Automobile / Truck

### **Chrysler**

1953-12-VOLT-C-58,C-59 DOME-LAMP Automobile

1953-12-VOLT-C58,C59 DOME-LAMP Automobile

1953-C-59 MAP-LAMP Automobile

1953-C59 MAP-LAMP Automobile

1954-1066 MAP-LAMP Automobile

1954-12-VOLT-C-66 DOME-LAMP Automobile

1954-12-VOLT-C66 DOME-LAMP Automobile

1955-12-VOLT-C-70 MAP-LAMP Automobile

1955-12-VOLT-C70 MAP-LAMP Automobile

### **GMC**

1946-COACHES-TD-3206,3609,4007,4506;TG-3206,3609;PD,PDA,PG,PGA DOME-LAMP Automobile / Truck

1946-COACHES-TD3206,3609,4007,4506;TG3206,3609;-

PD,PDA,PG,PGA DOME-LAMP Automobile / Truck

1946-COACHES-

TD3206,3609,4007,4506;TG3206,3609;PD,PDA,PG,PGA DOME-LAMP Automobile / Truck

1947-COACHES-TD-3206,3609,4007,4506;TG-

3206,3609;PD,PDA,PG,PGA DOME-LAMP Automobile / Truck

1947-COACHES-TD3206,3609,4007,4506;TG3206,3609;-

PD,PDA,PG,PGA DOME-LAMP Automobile / Truck

1947-COACHES-

TD3206,3609,4007,4506;TG3206,3609;PD,PDA,PG,PGA DOME-LAMP Automobile / Truck

1955-12-VOLT DOME-LAMP Automobile / Truck

1956-12-VOLT DOME-LAMP Automobile / Truck

1957-12-VOLT DOME-LAMP Automobile / Truck

### **White**

1942-12-VOLT-WA DOME-LAMP Automobile / Truck

1946-12-VOLT-WA DOME-LAMP Automobile / Truck

1946-12-VOLT-WB DOME-LAMP Automobile / Truck

STANLEY-4522

1947-12-VOLT-WA DOME-LAMP Automobile / Truck  
1947-12-VOLT-WB DOME-LAMP Automobile / Truck  
1948-12-VOLT-WB DOME-LAMP Automobile / Truck  
1949-12-VOLT DOME-LAMP Automobile / Truck  
1950-12-VOLT-WC-28-TOWC-32 DOME-LAMP Automobile / Truck  
1950-12-VOLT-WC28TOWC32 DOME-LAMP Automobile / Truck

# BA15d

double contact bayonet  
DC bayonet  
double contact candelabra bayonet  
SBC (British small bayonet cap)

IEC7004-11  
DIN49721

IEC7005-13  
DIN49642T6

A19A  
A19B  
A19C  
A19D  
B15d  
SBC  
DC  
BD

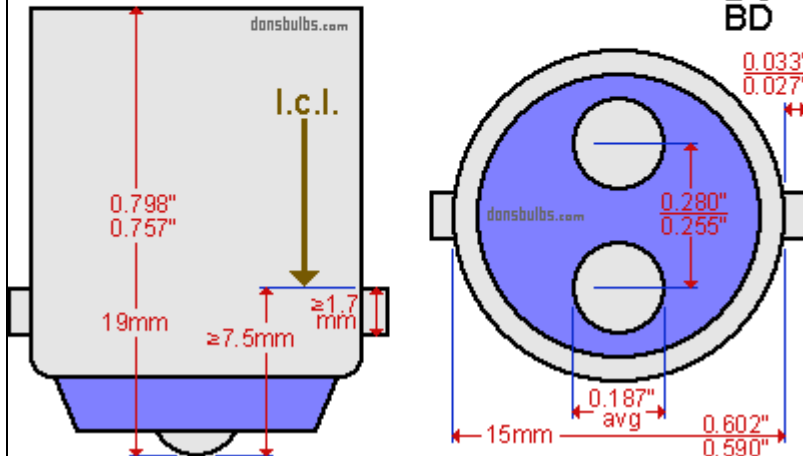

industry standards for base:

**BA15d** - Double Contact Candelabra Bayonet (or D.C.Bayonet)  
(not to scale)

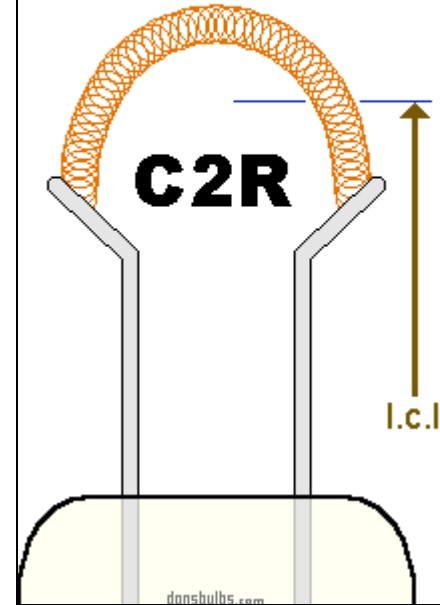

typical shape of **C2R** filament (not to scale)